



**International Luge Federation**

**IRO  
INTERNATIONAL  
LUGE REGULATIONS  
- ARTIFICIAL TRACK -**

**2014 Edition**

**[www.fil-luge.org](http://www.fil-luge.org)**

Approved at the 62<sup>nd</sup> FIL Congress on June 20, 2014  
in Innsbruck / Austria

**2014 Edition  
International Luge Regulations  
Artificial Track**

<b>§ 1</b>	<b>General Regulations</b> .....	3
<b>§ 2</b>	<b>FIL Competitions, Awarding</b>	
	1. FIL Competitions .....	5
	2. Procedure for the Awarding of FIL Competitions.....	5
<b>§ 3</b>	<b>Competition Regulations</b>	
	1. Disciplines .....	6
	2. Competitions Runs.....	6
	3. Regulations for Eligibility.....	6
	4. Age Requirements .....	6
	5. Seeded Groups .....	7
	6. Competition Program .....	8
	7. Cancellations, Competition Schedule .....	14
	8. Authorization to Participate in Training .....	14
	9. Authorization to Participate in Competition.....	14
	10. Rankings.....	14
<b>§ 4</b>	<b>Race Administration, Jury, Technical Delegate, International Judge</b>	
	1. Race Administration .....	16
	2. Jury.....	17
	3. Technical Delegate.....	17
	4. Combined Task of the Jury and Technical Delegates .....	18
	5. International Judge.....	18
<b>§ 5</b>	<b>Sled and Equipment</b>	
	1. General Regulations on Sled.....	19
	2. General Regulations on Equipment .....	25
	3. Start Numbers.....	27
	4. Inspection Procedure.....	27
<b>§ 6</b>	<b>Medical Service</b> .....	28
<b>§ 7</b>	<b>Advertising Regulations</b>	
	1. Applicability, Measuring Procedure .....	29
	2. Race Clothing.....	29
	3. Safety Helmet.....	29
	4. Visor .....	29
	5. Caps, Headbands and other Headgear .....	29
	6. Start Numbers.....	29
	7. Luge Shoes .....	30
	8. Gloves.....	30
	9. Racing Sled .....	30
	10. Athlete .....	30
	11. Forbidden Advertising .....	30
<b>§ 8</b>	<b>Training, Weigh-in, Individual Supplemental Weights</b>	
	1. International Training Courses .....	31
	2. Paid Training .....	31
	3. Official Training .....	31
	4. Weigh-In .....	33
	5. Individual Supplemental Weights.....	33

<b>§ 9</b>	<b>Race Preparation</b>	
	1. Entries.....	35
	2. Entry Fee .....	35
	3. Draw .....	35
<b>§ 10</b>	<b>Start, Finish, Timing, Results, Inspections</b>	
	1. Start .....	37
	2. Inspections at the Start .....	37
	3. Finish.....	39
	4. Inspections at the Finish.....	39
	5. General Rules .....	40
	6. Timing .....	42
	7. Results .....	43
<b>§ 11</b>	<b>Disqualification, Protests</b>	
	1. Violation of the Rules .....	44
	2. Protests .....	44
<b>§ 12</b>	<b>Awarding of Titles, Awards Ceremony</b>	
	1. Titles for World Championships.....	46
	2. Titles for Continental Championships .....	46
	3. Awarding of Titles in Case of a Reduction of Runs.....	46
	4. Certificates .....	46
	5. Medals .....	46
	6. Pins for Competitors and Officials .....	47
	7. Gifts of Honor and Mementos .....	47
	8. Awards Ceremony and Conclusion of the Event.....	47
<b>§ 13</b>	<b>Concluding Regulations</b> .....	48
 <b>Supplements:</b>		
	1. Regulation for Artificial Luge Tracks .....	49
	2. Rules for Instruction of International Judge .....	52
	3. Regulations for Audio-Visual Media Rights .....	54
	4. Olympic Rules .....	56
	5. Individual Weight Allowances .....	60

## § 1 General Regulations

1. The International Luge Regulations for Artificial Track (IRO) include the regulations for an orderly staging of all competitions of the sport of luge on artificial tracks including championships and international competitions of the FIL.  
It is also valid for the luge competitions during Olympic Winter Games (OWG), please refer to Supplement 4.
2. The sanctioning body and event organizers as well as the participating nations, sport clubs, teams, athletes, judges and all assigned helpers are obliged to adhere to the following regulations and use them during the staging of competitions on artificial tracks during Olympic Winter Games, FIL Championships and international competitions provided that there are no IOC regulations, FIL statutes or resolutions of FIL bodies ruling against it.
3. Athletes registered by their National Federations (NFs) can participate in all FIL competitions if they have a valid FIL license.  
The licenses are filled out by the respective National Federation on behalf of the FIL and are newly signed by the President of the respective NF or by a person authorized by him/her every season.  
With the signature of the National Federation's representative, it has to be confirmed that
  - a) the athlete is a member of his/her federation or one of its associated clubs,
  - b) the athlete is insured for practicing the sport of luge also in foreign countries,
  - c) the athlete has a medical certificate that is based on a medical examination conducted during the last 12 month or a subsequent medical examination in the event of a serious injury, and states that from a point of view of sports medicine, he/she is fit for practicing the sport of luge,
  - d) the athlete has received such a basic training that one could expect the athlete to be able to master luge tracks used for competitions in a safe way.The license only becomes valid after the athletes declare in writing that they bindingly acknowledge the statutes and regulations of the FIL, especially the IRO, the Law and Procedure Regulations of the FIL and that they have knowledge of the contents of all regulations.  
The license has to be submitted to the race director prior to each competition.
4. The event organizer authorized to stage FIL competitions is obligated to conclude a liability insurance for the entire duration of the competition in which the extent of the coverage is to be regulated through a written agreement.  
Any liability of the FIL will be explicitly excluded.
5. All national federations have the right to apply for the staging of FIL Championships and international competitions according to the regulations of the IRO.  
With the application to host an event, the respective National Federation acknowledges the IRO regulations and all other FIL regulations.  
Deviations from these regulations only become effective if they are explicitly approved by the FIL bodies responsible according to the statutes.
6. Athletes, FIL officials, National Federations, physicians, coaches, managers and other participants in the sport of luge are obligated to comply to the Anti-Doping Code of the FIL during and outside competitions.
7. Each participating athlete and official must behave fairly and in a sportsmanship like manner during a competition.
8. In case of discrepancies between the text of the IRO and the text of other FIL regulations or instructions of FIL bodies, the regulations of the IRO are decisive unless previous regulations of the FIL statutes state otherwise.

9. The word “athlete” used in the IRO includes both female and male competitors.
10. The sport year of the FIL starts on July 1st and ends on June 30th of the following year.
11. Violations against the regulations of the IRO result in disqualifications and/or other sanctions, which are specified in the Law and Procedure Regulations.

**1. FIL Competitions**

- 1.1 **Luge competitions during Olympic Winter Games (OWG)**
- 1.2 **FIL Championships, Rotation**
- 1.2.1 World Championships (FIL WCh)
  - ♦ in each sport year, with the exception of the year in which the OWG will be staged
- 1.2.2 Continental Championships (currently European Championships (ECh) / America Pacific Championships (APCh))
  - ♦ in every sport's year as "Race in Race" / World Cup (WC)
- 1.2.3 Junior World Championships (JWCh)
  - ♦ in each sport's year
- 1.2.4 Continental Championships Juniors (currently European Juniors Championships (JECh) / Junior America Pacific Championships (JAPCh))
  - ♦ in every sport's year as "Race in Race" / Juniors World Cup (JWC)
- 1.2.5 U23-World Championships
  - ♦ in each sport year, except in the sport year in which the OWG take place as "Race in Race" / FIL WCh

**FIL Championships (numbering)**

The Championships are numbered in a continuous order even if awarded championships are cancelled:

45 <sup>th</sup> WCh 2015	46 <sup>th</sup> WCh 2016	47 <sup>th</sup> WCh 2017
46 <sup>th</sup> ECh 2015	47 <sup>th</sup> ECh 2016	48 <sup>th</sup> WCh 2017
30 <sup>th</sup> JWCh 2015	31 <sup>th</sup> JWCh 2016	32 <sup>th</sup> WCh 2017
36 <sup>th</sup> JECh 2015	37 <sup>th</sup> JECh 2016	38 <sup>th</sup> WCh 2017
4 <sup>th</sup> APCh 2014/15	5 <sup>th</sup> APCh 2015/16	6 <sup>th</sup> APCh 2016/17
4 <sup>th</sup> JAPCh 2014/15	5 <sup>th</sup> JAPCh 2015/16	6 <sup>th</sup> JAPCh 2016/17

**1.3 International Competitions**

- 1.3.1 World Cup (WC)

The staging of World Cup races in blocks is allowed (i.e. three World Cup races in two weeks).
- 1.3.2 Team Relay World Cup (TWC)
- 1.3.3 Sprint World Cup (SWC)
- 1.3.4 Junior World Cup (JWC)
  - ♦ 4 - 6 races
- 1.3.5 Youth A World Cup (YAWC)
  - ♦ 4 - 6 races
  - ♦ 1 drop result in the event of 5 or more YAWC competitions

Junior World Cup and Youth A World Cup are staged in one event.
- 1.3.6 Nations Cup (NC)

World Cup and Nations Cup are staged in one event.
- 1.3.7 Three-Tracks Tournament (Dreibahnen-Tournee DT)
- 1.3.8 FIL Youth Games
- 1.3.9 Other international competitions

**2. Procedure for the awarding of FIL Competitions**

- 2.1 The FIL Congress awards the FIL World Championships and the Junior World Championships a maximum of 4 years in advance.

The awarding is done upon written application from the National Federation.  
The application according to the current form has to be submitted to the President of the FIL twelve weeks prior to the Congress.
- 2.2 The Executive Board awards the World Cup races with corresponding bidding criteria upon application by the National Federations.
- 2.3 All other FIL competitions are confirmed by the Executive Board.

**§ 3 Competition Regulations**

**1. Disciplines**

1.1 FIL competitions are staged in the following disciplines:

- ♦ Women - Singles
- ♦ Men - Singles
- ♦ Doubles
- ♦ Team Relay (§ 3 point 6.4)
- ♦ Junior Team competition (§ 3 point 6.5)

1.1.1 The Team Relay competition is obligatory during FIL WCh, ECh, and JWCh.

**2. Competition Runs**

	Singles	Doubles	Team Relay / Team Competition
FIL Championships	2	2	1
International Competitions	2	2	1

2.1 If a run is cancelled, disqualifications and eliminations as a result of a crash that have occurred during this run are not valid.

**3. Regulations for Eligibility**

	Women	Men	Doubles
3.1 FIL Championships	4	4	3
3.2 World Cup	4	5	3
3.3 Nations Cup refer to § 3 point 6.2 Additional starters allowed for NC	2	3	2
♦ Additional starters will not be awarded WC points			
3.4 Junior World Cup / Youth A World Cup:			
	Junior	Youth A	Together
Men's singles	6	6	maximum 10
Women's singles	5	5	maximum 8
Doubles	3	3	6

**4. Age Requirements**

4.1 FIL competitions are staged in the following age classes:

- ♦ General Class
- ♦ Juniors
- ♦ Youth A
- ♦ Youth B
- ♦ Youth C
- ♦ Youth D
- ♦ Seniors

4.2 Athletes who compete in youth and junior competitions must belong to the following age classes:

Juniors	Maximum Age	Year of Event - 20
	Minimum Age	Year of Event - 19
Youth A	Maximum Age	Year of Event - 18
	Minimum Age	Year of Event - 15
Youth B	Maximum Age	Year of Event - 14
	Minimum Age	Year of Event - 13
Youth C	Maximum Age	Year of Event - 12
	Minimum Age	Year of Event - 11
Youth D	Maximum Age	Year of Event - 10

(Minimum age and maximum age = age class)

4.2.1 During a competition taking place at the beginning of the season (July 1st - December 31st), the athlete belongs to the age class valid for him/her during a competition starting on the following 1st of January.

4.2.2 Athletes belonging to the Youth Class A are eligible to start in the Junior Class.

4.2.3 Athletes belonging to the Youth Class B are eligible to start in the Youth Class A. They can start with a 14 kg youth sled or a 16 kg youth sled B and/or a 24 kg youth double sled respectively.

4.2.4 The Youth Classes C and D may only start with a 14 kg youth sled and a 24 kg double sled in their classes.

4.3 For the OWG, FIL Championships and international competitions in General Class, athletes must have reached their fifteenth (15th) birthday during the sport year (§ 1, 10).

4.4 During the staging of competitions for seniors, athletes must have reached their 35th birthday.

## 5. **Seeded Groups**

5.1 During FIL competitions, seeded groups will start in all disciplines in the General Class, Junior and Youth A Class except in the Team Relay competition and in the team competition.

### 5.2 **Composition of seeded groups at FIL Championships and World Cup races (General Class)**

15 men  
12 women  
12 doubles

The seeded groups are set up by name. The names of athletes from the seeded groups are to be confirmed by the team captain before each draw.

### 5.3 **Composition of seeded groups at Junior World Championships, Junior World Cups, and Youth A World Cups**

JWCh and JWC/YAWC:

Group A = twelve (12) athletes and/or double teams as per name (JWCh § 3, 6.3.1.3)

JWC/YAWC:

Group B = athletes and/or double teams with JWC/YAWC points as per name

Remaining group = athletes and/or double teams without JWC/YAWC points as per name

The names of athletes from the seeded groups are to be confirmed by the team captain before each draw.

### 5.4 **Calculation of seeded places**

The current positions in the seeded groups General Class (seeded list) result from the World Cup point ranking of the three previous World Cup races. The points from the Sprint World Cup do not count in the determination of the current places for the seeded groups.

For the Junior Class and Youth A Class, the current positions in the seeded groups A and B (seeded list) result from the current Junior or Youth A World Cup point ranking.



For the 1<sup>st</sup> Junior World Cup and Youth A World Cup, the overall World Cup ranking of the previous season is valid.  
Beginners will start in the remaining group.

- 5.5 Junior World Championships, Junior World Cup, and Youth A World Cup: The seeded groups will generally be filled up to their full number.  
In the absence of an athlete, the next ranked athlete moves up.

## **6. Competition Program**

### **6.1 FIL World Championships in General Class**

Preliminary run:

- ♦ The seeded groups do not participate in the preliminary run; all other athletes determine their start position in the preliminary run for the 1<sup>st</sup> competition run.
- ♦ Start order according to the current seeded list, best place to last place. If athletes are tied in points, the start order is determined by a draw by the jury.
- ♦ Athletes without WC points will be placed at the end of the start list according to a draw.

Seeded group: In this group, the start order is determined by a draw; in doing so, the men's draw will be done in two groups (1 - 7 + 8 - 15), Women 1 - 12, Doubles 1 - 12.

In all disciplines, the 1<sup>st</sup> competition run will be as follows:

Men	1 - 7, 8 - 15,	16 - last place according to placing in preliminary run
Women	1 - 12,	13 - last place according to placing in preliminary run
Doubles	1 - 12,	13 - last place according to placing in preliminary run

Start order for the 2<sup>nd</sup> competition run

Men	25 - 1 according to placing in 1 <sup>st</sup> competition run
Women	20 - 1 according to placing in 1 <sup>st</sup> competition run
Doubles	18 - 1 according to placing in 1 <sup>st</sup> competition run

Athletes, which do not qualify for the 2<sup>nd</sup> competition run, will be ranked according to their placing in the 1<sup>st</sup> competition run.

### **6.2 World Cup in General Class / Nations Cup**

#### **6.2.1 Nations Cup / Qualification for World Cup**

Nations Cup and Qualification for the World Cup race will be carried out in one run.

- The qualification will take place if more than 17 men, 12 women and 12 doubles (without additional starters) are at the start.
- If the field of participants is smaller than the number of participants allowed to participate in the WC, then the result from the Nations Cup is drawn on to determine the start position in the WC race (6.2.6).
- Should an athlete not reach an end time, then he will be allocated the last start position before the seeded group. Should more than one athlete crash, then the start order of the crashed athletes will be drawn by the jury.

#### **6.2.2 Participation**

Athletes of the seeded group do not participate in the Nations Cup/Qualification.

In the absence of athletes from the seeded group, no athlete will move up.

For all other athletes (not for additional starters), the Nations Cup is considered as the qualification for the World Cup.

#### **6.2.3 Start order for the Nations Cup / Qualification for World Cup**

The start order arises from the current list of seeded groups:

Men - 16<sup>th</sup> place to the end / Women - 13<sup>th</sup> place to the end / Doubles - 13<sup>th</sup> place to the end,

Afterwards, athletes who do not come from the seeded list will start, these athletes will be drawn. Additional starters will be placed at the end of the start list according to a draw.

#### **6.2.4 Qualification for World Cup races**

The fastest 17 men, 12 women and 12 doubles will qualify for participation in World Cup races.

In the absence of athletes of the seeded group, the qualified participants will be increased by this number.

- ♦ Additional starters cannot qualify for the World Cup race.

6.2.5 Participation in World Cup races

	Men (32)	Women (24)	Doubles (24)
Seeded Group	15	12	12
Qualification / NC	17	12	12

The size of the field will be adjusted only by a tie in points or placing and also in the case of the absence of athletes of the seeded group.

6.2.6 Start order for World Cup races

1<sup>st</sup> competition run:

- ♦ Last place to first place from the Qualification or NC
- ♦ Seeded group according to draw

2<sup>nd</sup> competition run:

- ♦ According to the results of the 1<sup>st</sup> competition run, last place to first place.

If there is no Nations Cup, then

1<sup>st</sup> competition run:

- ♦ Last place to seeded group from current seeded list
- ♦ Athletes without World Cup points according to a draw
- ♦ Seeded group according to draw

2<sup>nd</sup> competition run:

- ♦ According to the results of the 1<sup>st</sup> competition run, last place to first place.

6.2.7 Nations Cup: Allocation of World Cup points for non-qualified athletes

Non-qualified athletes are awarded the following World Cup points:

Men: 18<sup>th</sup> place in Nations Cup = 8 World Cup points etc. according to list in § 3 point 10.1

Women: 13<sup>th</sup> place in Nations Cup = 16 World Cup points etc. according to list in § 3 point 10.1

Doubles: 13<sup>th</sup> place in Nations Cup = 16 World Cup points etc. according to list in § 3 point 10.1

If the size of the World Cup field is adjusted (see point 6.2.5), then points awarded to Nations Cup athletes will be adjusted accordingly.

- ♦ Additional starters will not be awarded any World Cup points.

6.2.8 World Cup: Allocation of World Cup points in the case of a default

Athletes who participate in the World Cup, including seeded and athletes qualified through the Nations Cup, but who do not achieve a result because of a crash in the first or second run, or a DNS in the either run, will be awarded the amount of World Cup points which are normally given to the top ranked non-WC qualified athlete in each discipline (Point 6.2.7). For seeded athletes this rule (DNS) shall only be applied if the athlete starts in the final training for seeded athletes.

This rule does not apply:

- in the case of a disqualification
- for the Sprint World Cup

6.3 **Junior World Cup (JWC), Youth A World Cup (YAWC) and Junior World Championships (JWCh)**

**Grid Race** (Junior World Cup)

In the Grid Race (1 run) the start positions for the JWC race are determined.

- The Grid Race replaces the seventh (last) training run for the Juniors.
- The start positions for the JWC race are awarded through the ranking in the Grid race.
- Start order according to the current list of seeded athletes 1 - end
  - ♦ Group A, 1 - 12, seeded group
  - ♦ Group B, 13 - x, according to the seeded list
  - ♦ Rest group, athletes without JWC points (draw at the end of the start list)
- In the case of a tie in points, the start order is drawn.

Start numbers JWC:

- The start number allocation for the JWC race takes place through the placement in the Grid race.

- The athletes of group A approached the starting places 1 - 12 and the athletes of the B and the rest group starting places 13 - end.
- The B and rest groups are considered to be a group together.
- In the case of a crash, the athlete receives the last start number assigned to his group.
- In the case of a disqualification, the athlete is assigned to the last grid position in the field of participants.
- In the case of multiple defaults (DNF,DSQ), the start order of these athletes will be drawn
- At a double World Cup, only one Grid Race is staged, the start position is valid for both JWC races.
- Should the Grid Race not take place, the start order for the JWC in group A is drawn, group B starts according to the placement in the current overall World Cup. The rest group is drawn.
- Start order 1<sup>st</sup> JWC, if the Grid Race does not take place:  
Group A, - Group B, - athletes required to move up \*, - rest group.

#### **Junior World Cup, Start Order**

1<sup>st</sup> competition run:

- ◆ Places 1 - 12, according to placing in the grid race (only Athletes from the seeded group)
- ◆ Places 13 - end, Athletes from the B and Rest group according to placing in the Grid Race

2<sup>nd</sup> competition run:

- ◆ places 32 - 1, 33 to the end, according to the standings of the 1<sup>st</sup> run

Regulation for athletes moving up from Youth A for the 1st JWC (this regulation only applies to the 1<sup>st</sup> JWC of every season)

Start Order Grid race

- ◆ Group A 1 - 12, seeded according to overall JWC point standings (previous year)
- ◆ Group B 13 - x, according to overall JWC point standings (previous year)
- ◆ \*athletes required to move up, according to overall YAWC point standings (previous year)
- ◆ Rest Group new athletes (by draw)

(\*Athletes moving up from the Youth A Class to Junior Class, changing classes)

After the 1<sup>st</sup> JWC in the current season, all athletes without JWC points are drawn in the rest group.

#### **Youth A World Cup, Start Order**

1<sup>st</sup> competition run:

- ◆ Group A 1 - 12 seeded (by draw)
- ◆ Group B 13 - x according to current WC point standings
- ◆ Rest group new athletes (by draw)

2<sup>nd</sup> competition run:

- ◆ places 32 - 1, 33 to the end, of the standings of the 1<sup>st</sup> run

### **6.3.1 Junior World Championships (JWCh)**

#### **6.3.1.1 Procedure JWCh**

- 6 official training runs for all athletes
- + Preliminary run for the non-seeded athletes
- + final training for the seeded athletes (1 run)

The seeded final training is held in the disciplines. Start order according to the current JWC point standings, places 1 - 12 (men, women and doubles).

#### **6.3.1.2 Preliminary run:**

The seeded group A does not participate in the preliminary run, all other athletes determine their start number for the 1st competition run in the preliminary run.

- Start order according to the current seeded list, best place to last place. In the event of a tie in points, the jury draws the start numbers.
- Athletes without points are drawn at the end of the starting field.

- Non-seeded athletes from the General Class who do not have any JWC points, must participate in the preliminary run.  
The start order is drawn, start number 1 - to...
- 6.3.1.3 Draw
  - Seeded group A: the start order for the 1st competition run is drawn.
  - Athletes from the General Class who do not have any JWC points but are currently in the seeded group in the General Class in WC, are drawn in the seeded group A. The seeded group A is increased by this number.
- 6.3.1.4 Start order JWCh:
  - 1st competition run
    - 1 - 12 seeded group A (by draw)
    - 13 - end according to the standings in the preliminary run (first to last)
  - 2nd competition run
    - Men: 25 - 1 according to placing in the 1st competition run
    - Women: 25 - 1 according to placing in the 1st competition run
    - Doubles: 20 - 1 according to placing in the 1st competition run
- 6.3.1.5 Athletes who do not qualify for the 2nd competition run are ranked according to the standings in the 1st competition run.
- 6.4 **Course of Team Relay Competition**
  - 6.4.1 Eligibility to participate
    - Only one Team Relay team per nation may participate in the competition (1 man, 1 woman, 1 doubles)
    - Athletes participating in the Team Relay competition must be qualified for the WC / NC or for the FIL championships.
    - No additional starters are allowed in the Relay competition.
  - 6.4.2 Registration/entries
    - The day before the Team Relay competition, all NFs participating have to register their teams by name in writing at the latest by 5:00 p.m. or at most 10 minutes after the last competition of the day is completed, whichever comes later.
    - After the registration deadline, a substitution is possible for justified reason, e.g. injury or illness of an athlete.
    - Athletes who complete their competition on the same day of the Team Relay must be registered in writing with the Sport Coordinator at most 10 minutes after their competition ends.
  - 6.4.3 Time of Team Relay competition
    - The Team Relay competition is staged in one run as the event's last discipline.
    - Changes of the time when the competition must be staged by the event organizer are determined by the FIL.
  - 6.4.4 Determination of the "nations ranking" for the Team Relay World Cup
    - The "Team Relay nations ranking" is determined as follows:
      - current World Cup point standings in the singles and doubles disciplines;
      - only the best ranked athletes are determined for each NF (1 woman, 1 man, 1 doubles);
      - the points of the best placed athletes of each NF are added;
      - the total of points is the placing in the "Team Relay nations ranking";
      - if a Team Relay competition is held on the 1st World Cup weekend the "Team Relay nations ranking" is calculated on the basis of the World Cup point standings of the previous season.
  - 6.4.4.1 For determining the "nations ranking" for the Team Relay competition at FIL WCh (General Class) and OWG:
    - the ranking in the three individual disciplines (women's/men's singles and doubles) in the current FIL WCh or OWG is valid;
    - per NF only the best placed athletes are derived from the results: 1 woman, 1 man, 1 doubles;
    - the points (§ 3, 10.1) of the best placed athletes or the respective NF are added together;
    - the total determines the ranking in the Team Relay nations ranking for the FIL WCh / OWG.

- 6.4.5 Start order World Cup
- At the 1st Team Relay competition the start order follows the “Team Relay nations ranking” (point 6.4.4) in reversed order (last ranked to rank 1).
  - After the 1st Team Relay WC, the start order is the reverse order of the current Team Relay World Cup rankings (last to first place).
  - New teams/NFs start first by draw.
  - Order of disciplines per team: women’s singles / men’s singles / doubles
- 6.4.6 Start order FIL WCh (General Class) and OWG
- according to the nations ranking for the Team Relay at FIL WCh and OWG (§3, 6.4.4.1) in reverse order. In the case of a tie, the race ranking in doubles determines the placement in the nations ranking.
- 6.4.7 Competition schedule
- All three sleds of one team start one after the other from one start height.
  - The first sled starts in a >normal< way within 30 sec; the start gate is already open. Arriving at the finish, the athlete releases the contact to open the start gate by hand at the touch pad. The time is still running.
  - The second sled may start as soon as the gate opens.
  - The start of the third and last starter is analogous to the start of the second one.
  - Starters number 2 and 3 receive two signals (announcements / sound of a horn) indicating where the slider currently is, as an orientation to the time approximately remaining until the start.
  - As soon as the third starter reaches the touch pad, the time stops and the overall time for the relay team is determined.
  - Between the first and the second starter as well as between the second and the third starter a split time is kept between the opening of the start gate and the first light barrier in which the reaction time is registered.
  - The start interval per team is fixed at approx. 4 minutes.
  - If an athlete does not trigger the touch pad with his hand, that Relay team is disqualified.
- 6.4.8 Start order / Start preparation
- The athlete enters the start area and takes the starting position alone with his/her sled.
  - Any help by a coach is prohibited.
  - It is only permitted to hand the sled over into the start area.
- Start process
- An athlete may only start when the start gate opens, the set of lights turns to green, and/or an acoustic signal is heard.
  - In the starting position, the athlete’s sled or toe-caps may not touch/cross the marked line.
- Start area
- At each track, the start area is defined and marked by the TD.
  - Coaches are not allowed within the start area.
  - Walkie talkies or cell phones which assist athletes are forbidden in the immediate start area.
  - During the races only those athletes starting next are allowed to enter the start area.
  - Except for the start leader and the responsible FIL official/judge no other person is allowed in the start area.
- False start
- In order to prevent a false start, a marking line is drawn between the start handles and start gate. Before the gate opens, this line may neither be touched by the sled (front end of runner) nor by the athlete (foot tip).
  - The FIL official/judge who watches and supervises the start process will take note of a false start as the first authority and report it to the race director.
  - The start process may be supervised with the help of a video unit. In case of a dispute, the video will be evaluated in order to identify a false start.
  - A false start occurs if the marking line is touched before the opening of the start gate.
  - A false start will result in the disqualification of the Relay Team.
  - The team will complete the race regardless if a false start is called.
- 6.4.9 Determination of the overall ranking
- The points achieved within the competitions that are held on the World Cup weekends are added

up (IRO §3, 10.6). European Championships and World Championships are not taken into account in the overall ranking.

## 6.5 Team Competition Program in the Junior Class

- 6.5.1 Eligibility to participate (§ 3 point 3.1 and 3.4)  
A team consists of four athletes (1 man, 1 woman, and 1 doubles). It is not permitted to start in two disciplines.  
Two nations which are not able to form their own team may come together to form a team.  
A NF that has one team cannot be represented with athletes in a second team.
- 6.5.2 Registration for the team competition
- The participating NFs must register their team in writing by 5:00 pm the day before the team competition. If the competitions the day before the team competition run later, the teams must be registered no later than 10 minutes after the last competition has ended.
  - After the registration deadline, substitution is possible for justified reasons, e.g. injury or illness of an athlete.
  - The registration of those athletes who complete their competition on the same day must be made in writing to the TD Juniors no later than 10 minutes after completion of the competition.
- 6.5.3 Additional training run  
If the team competition is held before the individual disciplines, athletes who have not participated in the team competition could receive an additional training run.  
The decision is made by the race director after consultation with the jury.
- 6.5.4 Order of nations (when the team competition is held in the disciplines)  
The order of nations will be drawn.  
First discipline - start number 1 to end  
Second discipline - end to start number 1  
Third discipline - according to intermediate ranking beginning with last ranked team.  
The order of the individual disciplines is variable.
- 6.5.5 Start heights Team competition in Team Relay format
- If possible, all three disciplines start from the same start height in the Team Relay format (woman, man, doubles) but without the finish touch pad.
  - If the equipment is available, the start is done with a start gate (reaction start).
- Start order
- At the 1st Team Relay competition the start order follows the “Team Relay nations ranking” (Point 6.4.4) in reverse order (last ranked to rank 1).
  - After the 1st Team Relay WC, the start order is the reverse order of the current Team Relay World Cup rankings (last to first place).
  - New teams/NFs start first by draw.
  - The total time for the team is calculated by adding the three run times.
  - Order of disciplines per team: women’s singles / men’s singles / doubles.
- 6.5.6 The team competition is fundamentally held as the last discipline of the event.
- 6.5.7 At the JWCh, the team competition (point 6.5.5) can be held instead of the Team Relay (6.4) if the relay equipment is not available.  
The start order is the reverse order of the “nations ranking for the Team Relay” (Point 6.4.4).
- If a Team Relay is held at the JWCh, a Team Relay training must be held during the official training.
- 6.5.8 Refer to point 10.6 for the calculation of results and overall results of the team competition.

## 6.6 Sprint World Cup (SWC)

The procedure for the Sprint World Cup is regulated in the Sprint World Cup rules. The rules are part of the IRO (Congress resolution Innsbruck 2014).

**7. Cancellations, Competition Schedule**

- 7.1 The race director is authorized in agreement with the jury and the technical delegate, to adapt the start order of the race runs to television requirements and weather conditions in order to ensure a fair race for everybody involved.
- 7.2 The race director can decide to cancel a discipline upon consultation with the technical delegates.

**8. Authorization to participate in training**

An athlete is authorized to participate in training if

- ♦ he/she fulfills the general athletic demands of the sport and has successfully completed a FIL luge school. The confirmation is provided by the responsible FIL coach. If in doubt, an athletics test will be carried out by the responsible FIL coach, of which the athlete must fulfill the minimum requirements.
- ♦ he/she has not started for another nation during the respective sport year,
- ♦ a valid license is submitted,
- ♦ the age class regulations are adhered to,
- ♦ he/she has been registered for the competition in correspondence with the regulations for eligibility under § 3 point 3. (Exception: Athletes who do not participate in the competition, but start as forerunners).

**9. Authorization to participate in competition**

An athlete is authorized to participate in a competition, if

- ♦ he/she participated in the training,
- ♦ he/she achieved a time difference of up to a maximum of 7% from the group's best time in one of his/her official training runs in the respective group during one of their scheduled training sessions,  
For Juniors / Youth A, this rule is only applied at the Junior World Championships (JWCh) and the Youth Olympic Games (YOG),
- ♦ he/she has completed two training runs,  
This rule is valid for all Junior and Youth Competitions
- ♦ At one event, an athlete may only start in one age group (JWC or YAWC).  
Exception: In the Junior Team Competition, Youth A athletes can also start if the Youth A discipline start height is the same as the competition start height of the team competition.
- ♦ he/she does not participate as an official in this competition.

**10. Rankings**

**10.1 World Cup**

For the results achieved in a World Cup, Team Relay, or Sprint World Cup competition, the following points per race are awarded:

Men / Women / Doubles / Team Relay

1st Place	100 Points	15th Place	26 Points	29th Place	12 Points
2nd Place	85 Points	16th Place	25 Points	30th Place	11 Points
3rd Place	70 Points	17th Place	24 Points	31st Place	10 Points
4th Place	60 Points	18th Place	23 Points	32nd Place	9 Points
5th Place	55 Points	19th Place	22 Points	33rd Place	8 Points
6th Place	50 Points	20th Place	21 Points	34th Place	7 Points
7th Place	46 Points	21st Place	20 Points	35th Place	6 Points
8th Place	42 Points	22nd Place	19 Points	36th Place	5 Points
9th Place	39 Points	23rd Place	18 Points	37th Place	4 Points
10th Place	36 Points	24th Place	17 Points	38th Place	3 Points
11th Place	34 Points	25th Place	16 Points	39th Place	2 Points
12th Place	32 Points	26th Place	15 Points	40th Place	1 Point
13th Place	30 Points	27th Place	14 Points	41st Place	and continuing
14th Place	28 Points	28th Place	13 Points		with 1 point each

- ◆ For World Cup ranking, no results can be dropped.
- ◆ In doubles, the teams are ranked.
- ◆ If a doubles team starts again with another athlete, this new team will be ranked separately.
- ◆ The winner of the overall World Cup is the athlete/athlete pair with the most points from the WC + SWC.
- ◆ The winner of the Team Relay overall World Cup is the team with the most points.
- ◆ Ties are awarded the same rank.

Athletes/Team Relays/Teams that are listed as a DNS for a specific event will not be recorded in the rankings for that event.

Athletes/Team Relays/Teams that are listed as a DNF or DSQ for a specific event will be shown in the rankings as either DNF or DSQ as the case may be.

#### Nations Ranking

For the nations ranking, the points of all athletes from a National Federation are added according to the overall World Cup ranking.

#### 10.2 **Junior World Cup**

- Ranking like World Cup.

#### 10.3 **Youth A World Cup**

- Ranking like World Cup.

#### 10.4 **Nations Cup**

- Ranking like World Cup,

- Allocation of World Cup points refer to § 3 point 6.2.7.

#### 10.5 **Three-Tracks Tournament (Dreibahnen-Tournee)**

- Ranking like World Cup.

#### 10.6 **Team Relay Competition / Team Competition**

The results of the Team Relay competition / team competition are based on the total cumulative time of the three sleds.

Overall rankings of nations will be made at the end of all competitions.

The points will be allocated according to the World Cup rankings.

Should there be a tie between two or more teams, the times from all competitions will be added and ranked accordingly.



**1. Race Administration**

The race administration includes the race director, start leader, finish leader, and chief of track.

**1.1 Race Director**

1.1.1 The race director is fully responsible for the staging of the competition.

1.1.2 For training and competition, the race director declares the track open, if

- ♦ the confirmation by the chief of track and the technical delegates has been submitted,
- ♦ all officials have taken their posts and the technical equipment has been found to be in working order after examination and/or testing,
- ♦ the facilities for the communication are available and at least the phone connection between start and finish is in working order,
- ♦ the medical service is available.

1.1.3 If the jury or the technical delegates detect deficiencies which influence the orderly staging of the event, the race director has to have the deficiencies remedied.

1.1.4 If accidents occur or if the technical equipment fails, the race director closes the track until proper continuation of the event is guaranteed.

1.1.5 The race director has the right to refer an athlete to the race doctor for a medical assessment if this athlete is injured or ill or if for any other reason, his/her start involves a specific risk to his/her health or life.

If the race doctor confirms a specific risk to the health or life of the athlete in writing, the race director is entitled to withdraw the permission to start in official training and/or competition from an athlete (§ 6 point 2).

1.1.6 The race director must inform the chairperson of the jury and the technical delegates of all incidents.

1.1.7 In case of violations against the IRO, the race director will make the initial necessary decisions.

He/she is obligated to personally convince himself/herself of the offence.

Items or corresponding pieces of evidence for a possible disqualification must be submitted to him/her by the judges, jury and respective technical delegate (§ 11 point 1.2).

1.1.8 The race director has the right, after consultation with the Technical Delegate, to bar an athlete from the training / competition if he/she cannot meet the demands of the track.

**1.2 Start Leader**

1.2.1 The start leader is responsible for overall supervision of the start area.

He/she is in charge of testing and weighing the sled and equipment of the athletes and is to supervise the start process.

1.2.2 The start leader shall immediately notify the race director of any infraction of the rules.

1.2.3 The start leader must be in command of the technical terms in English or German.

**1.3 Finish Leader**

1.3.1 The finish leader is responsible for coordinating all activities including the staging of the competition at the finish area as well as for the proper running of timing and controls at the finish.

1.3.2 The finish leader shall immediately notify the race director of any infraction of the rules.

1.3.3 The finish leader must be in command of the technical terms in English or German.

**1.4 Chief of Track**

1.4.1 The chief of track is responsible for flawless maintenance of the track during training and competition.

He hands over the track to the technical delegate.

1.4.2 He/she must immediately report reasons against use of the track to the race director.

1.4.3 The chief of track has to take care that the ice temperature during a competition run is kept constant by at least - 3° Celsius in the shade.

The technical delegate has to be informed about any changes of the ice temperature due to regulation in the refrigeration plant.

The ice temperature has to be visibly displayed within the start area.

## **2. Jury**

### **2.1 Appointment**

- 2.1.1 The members of the jury for the OWG / YOG, FIL World Championships (General Class), and Junior World Championships will be proposed by the Sport Commission. The Executive Board will make the final decision.
- 2.1.2 The proposed candidates must be members of a National Federation or a Commission of the FIL (Technical or Sport) and must have an International Judge License.
- 2.1.3 When staging an international competition, the authorized National Federation proposes three candidates to the FIL Executive Board.
- 2.1.4 The decision on the appointment to the jury will be confirmed in writing to the National Federation, the event organizer, and the nominated judges.

### **2.2 Composition**

- 2.2.1 The jury includes the chairperson and two additional members.
- 2.2.2 At all FIL competitions, the 3 members of the jury must belong to different National Federations.

### **2.3 Duties**

- 2.3.1 The jury is the highest authority present. In accordance with the IRO, it is charged with decision making power for the duration of a competition.
- 2.3.2 Members of the jury are not permitted to assume a technical function or a race official's position during an event.
- 2.3.3 Along with their supervisory duties, the jury makes a decision on all written protests with a simple majority vote.
- 2.3.4 Each member of the jury has access without prior notice to all technical equipment and facilities which are necessary for the staging of an event.
- 2.3.5 The jury must be available from the beginning of training. During Junior World Cups, the jury should be available for the last training, however they must be available for the draw at the latest.
- 2.3.6 If a jury member is not able to participate, the remaining jury members and the chairperson of the organization of the competition decide upon the assignment of a new jury member.
- 2.3.7 The chairperson of the jury has to completely fill out the race report and mail it according to the distribution code.

## **3. Technical Delegate**

### **3.1 Appointment**

- 3.1.1 Three technical delegates will be proposed by the Technical Commission for the OWG / YOG and FIL Championships (WM, EM, JWM). The Executive Board will make the final decision.
- 3.1.2 For all other FIL competitions (WC, JWC, YAWC), the FIL Executive Board will appoint **one** permanent technical delegate of the FIL.  
The organizing NF will appoint two additional technical delegates. These technical delegates will be responsible for individual tasks given to them by the permanent technical delegate, and they shall be available to the permanent technical delegate in an assisting function.

### **3.2 Composition**

- 3.2.1 The technical delegates are representatives of the FIL.  
They provide assistance to the event organizers through their expertise and via their supervisory and inspection duties, ensure technical observance of the IRO.
- 3.2.2 The technical delegates have to own an International Judge License.
- 3.2.3 The FIL always provides a full-time technical delegate at all competitions (FIL Championships, WC, JWC/YAWC). This technical delegate may not work for any other National Federation while performing his/her duties during training and competitions.
- 3.2.4 Technical delegates at OWG and FIL Championships must be members of the FIL Executive Board or Expert Commissions. One of the technical delegates should be a member of the FIL Technical Commission.

### **3.3 Duties**

- 3.3.1 The technical delegate has access without prior notice to all technical facilities and equipment necessary for the staging of an event.

- 3.3.2 During the days of training, the technical delegates, in agreement with the race director, must grant the National Federations the opportunity to have their sleds and equipment examined.
- 3.3.3 Before each training and competition run, the technical delegates must inspect the track and the facilities and will transfer the track to the race director only when the inspection has justified it and when the chief of track has handed the track over to the technical delegate.
- 3.3.4 The jury or the race director is to seek the expert opinion of the technical delegate about various decisions, protests and so forth (§ 11 point 1.2).

**4. Combined Task of the Jury and Technical Delegates**

Before all competitions, the race director, the chairperson of the jury, and the technical delegates have to determine the action plan for the jury and the technical delegates.

**5. International Judge**

- 5.1 Only judges possessing an FIL International Judge License may serve in a position of race leadership in FIL competitions.
- 5.2 International judges must officiate a minimum of one competition each sport year and attend repetitive training provided by the National Federations or the FIL once every two years, pertaining to changes in the IRO, to remain active.
- 5.3 International judges who have not officiated a competition or attended repetitive training pertaining to IRO changes for a period of five years will be withdrawn as an international judge and must re-acquire the International Judge License.
- 5.4 The National Federations must provide instruction for judges who wish to acquire the International Judge License or remain active.
- 5.5 National Federations which have no internationally approved judges to carry out FIL competitions must request international judges from the FIL for these competitions. According to the FIL travel cost reimbursement plan, compensation is to be paid by the NF staging the competition.

**1. General Regulations on the Sled**

1.1 The primary components of the sled are:

- ◆ 2 Runners
- ◆ 2 Steels
- ◆ Sling seat or pod seat
- ◆ 2 Bridges

The bridge consists of two or more parts for the purpose of alignment. These must be securely fixed by screws or bolts and may not be adjusted or changed during a run.

1.2 The steels can be comprised of one or several parts. If the steel comprises several parts, then these parts must be bonded, welded, or riveted together to form one piece.

- ◆ The steel has a max. length of 1200mm.
- ◆ The steel has a max. width of 50 mm and a min. width of 15 mm, 5 cm after the beginning of the steel and 5 cm before the end of the steel.
- ◆ The maximum height of the steel may not exceed 30 mm.
- ◆ The steel must be screwed/bolted to the runner by at least 4 screws/bolts.
- ◆ The first and last screw/bolt mounting the steel to the runner must be within 200 mm from the beginning and the end of the steel.
- ◆ The mounting screws/bolts may not be further than 400 mm apart.
- ◆ The steels may be drilled or milled lengthwise, however a margin must remain.
- ◆ The steel may not be cut crosswise.
- ◆ Guide pins and/or guide rails for stabilizing the steel are not allowed.

Refer to Sketch 1 a, 1 b und 5 for more details.

1.2.1 The gliding steel, blades and runners of the sled may not include any cushioning and/or suspension.

- ◆ This is also valid for individual parts connecting these items to each other as well as for the fastening of the bolts connecting the steel\* to the runner.
- ◆ Between the runner and the steel, only a continuous inlay, 1mm thick and 10 mm wide, to change the angle of the steel is permitted. The beginning and end of the inlay must be no longer than 5 cm measured from the beginning and the end of the steel.
- ◆ Inlays may be fixed with double-sided adhesive tape, but may not exceed 1mm with the adhesive tape.
- ◆ The gaps between the runner and the steel may measure up to 0.4 mm.
- ◆ There must be a connection between the steel and the runner after a max. of 5 cm measured from the beginning and the end of the steel as well as at every mounting bolt/screw.
- ◆ If the judge can insert the distance gauge 0.5mm into the empty space (gap) up to half of the width of the steel, this is reported to the TD and this sled is inspected by the TD in the finish area. If the distance gauge (0.5mm) is able to clear the empty space over the entire width of the steel, then this results in disqualification.
- ◆ The inlay between runner and steel is measured using a digital sliding caliper adjusted to 1.1 mm. Inserts that can be moved freely through the sliding caliper are classified as conforming to the rules.
- ◆ The area (connection) between runner and steel is not allowed to be covered - only 5 cm at the front and at the back end of the steels.

Refer to Sketch 1 b and 5 for more details

1.3 The weights including attached accessories are:

- ◆ Minimum 21 kg, maximum 25 kg for a singles sled
- ◆ Minimum 25 kg, maximum 30 kg for a doubles sled
- ◆ Maximum 16 kg, for a youth B sled
- ◆ Maximum 14 kg, for a youth sled
- ◆ Maximum 24 kg, for a youth double sled

The calculation of weight

- ♦ for a singles sled is 23 kg
- ♦ for a doubles sled is 27 kg

Missing or increased weight of the sled (+/- 2 kg) can be adjusted through the AW and RC (Race Clothing).

- ♦ Athletes belonging to the Youth Class B who are starting in the Youth Class A with a 14 kg youth sled (in singles) or with a 16 kg youth B sled and/or a 24 kg youth sled (in doubles) may not adjust the missing weight on the sled through additional weight.

- 1.4 The distance between the inner edges of the blades must not exceed 450 mm at any point (refer to sketch 5).
- 1.5 The maximum width of the sled, including shell and handles, must not exceed 550 mm at any point (refer to sketches 2 and 4).
- 1.6 In the interest of safety, the outer edges of the blades including the laminate must be rounded or sloped to a radius of at least 5 mm (refer to sketch 5).
- 1.7 Steering must result from use of the primary components of the sled mentioned in Section 1.1. On a doubles sled, steering may be supplemented by foot supports for the person on the back.
- 1.8 The foot supports for the back man of the doubles sled must not be longer than 300 mm. The allowed height of the runner in that area is not allowed to exceed 130 mm (sketch 1a). The width of the runner is not allowed to exceed 50 mm. (sketch 1a).
- 1.9 Use of an encased seat (pod) on the sled is allowed.
- ♦ The pod may not extend past in the shoulders in the back and in not over the front edge of the knee cap in the front.
  - ♦ For doubles, the front edge of the knee caps of the front man and the shoulders of the back man are the decisive measuring points.
  - ♦ The sitting position of the doubles athletes has to be one behind the other.
  - ♦ The length of terraced seat can reach to the end of the buttocks of the front man at the most.

- ♦ Positions:

Singles	supine
Doubles front man	sitting, knees extended, belt on
Doubles back man	supine

- ♦ Measurements:

<b>Measurements (clearance, width 90° to measuring table)</b>	<b>max.</b>
Pod width including handles	550 mm
Pod height singles including handles	120 mm
Pod height doubles	170 mm
Front edge pod - end of seat terrace	
Pod height doubles	120 mm
End of seat terrace - end of pod	

(Refer to Sketch 1 a, 2, 3 and 4)

- 1.10 The dimensions of the runner plus blade must not exceed 50 mm in width and 80 mm in height. The runner must be at least 25 mm wide from the area of the middle of the rear bridge to the middle of the forward bridge. Dimensions of the blades within this area are to be 30 mm maximum height and 15 mm minimum width including the required rounding. Checking of the runner dimensions is done in a right angle to the vertical and horizontal middle axis of the runner. Refer to Sketches 1 b and 5 for more details.
- 1.11 The weight of the upper-part of the sled (bridges with pod seat) must be connected all the way through on each leg of the bridge with a screw or a bolt. The mobility of the four bridge legs in the area of the screws or bolts is allowed by using a radial spherical bearing and/or a through-hole. Any other cushioning or suspension in this area is not allowed (refer to Sketch 6).
- 1.12 The rubber inserts which cover the leg of the bridge must be open on the bottom so that the stipulated free space is given (refer to sketch 6).
- 1.13 The drawings serve only as a visual representation of the regulated equipment measurements. They have no significance whatsoever for the testing process or for the construction of the equipment.
- 1.14 Drawings regarding the sled:

Sketch 1a

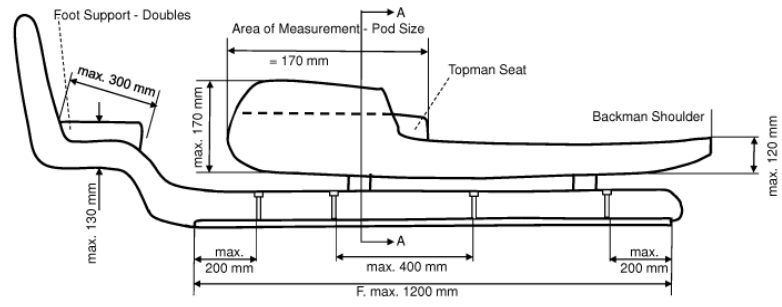

Sketch 1b

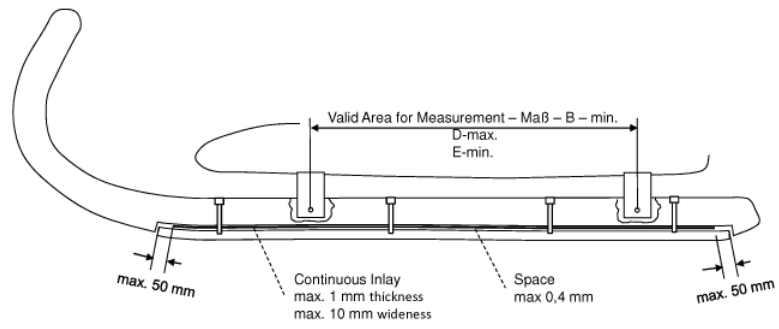

Sketch 2

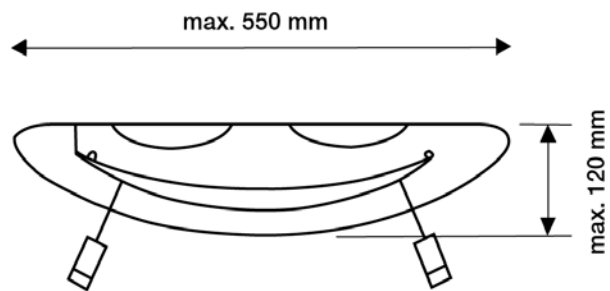

Sketch 3

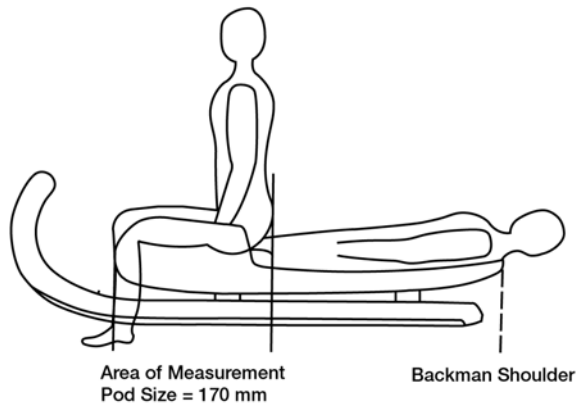

Sketch 4

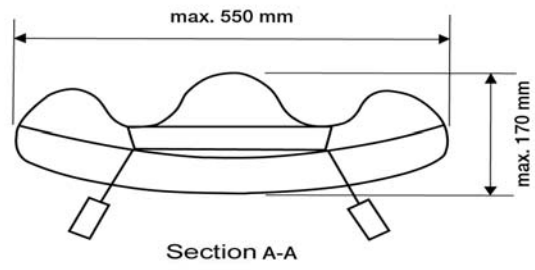



Sketch 5

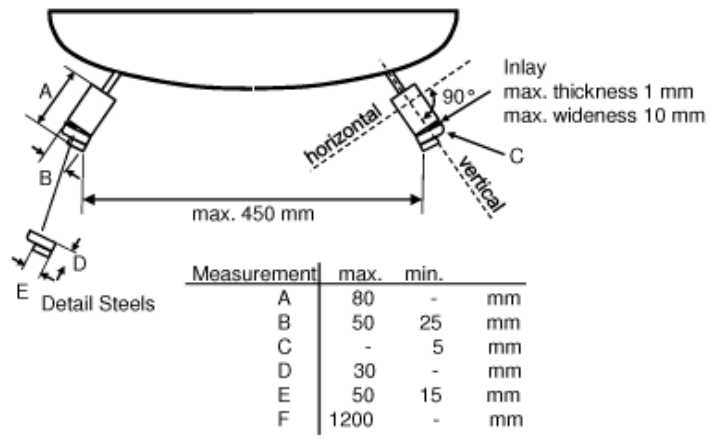

Sketch 6

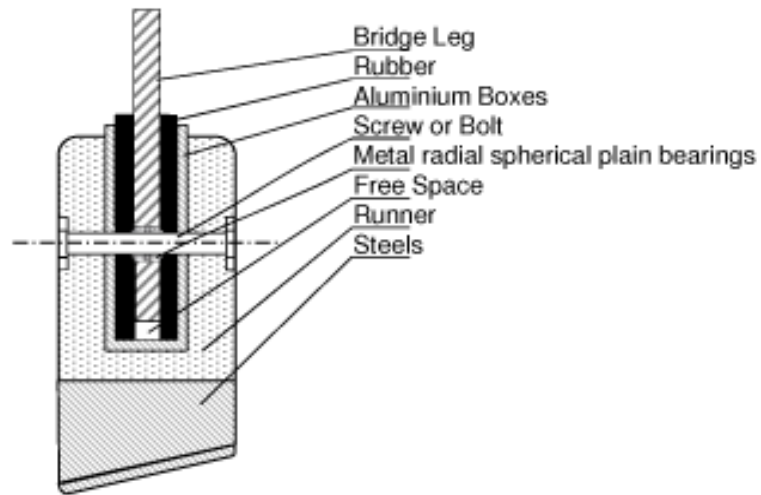

## 2. **General Regulations on Equipment**

### 2.1 **General**

- 2.1.1 All items of race clothing, including helmet and luge shoes, must conform to or be adapted to the body contours of the competitor.  
The wearing of visors is permitted.  
Aerodynamically formed connections between the head and upper body are not permitted.  
A neck strap is permitted; however, it may not lead to (or cause) an aerodynamically improved form of the race clothing.  
Each competitor must use proper race clothing in training and competition.

- 2.1.2 Additional protective equipment (pad(s)) must conform to the competitor's body contour and is permitted to be a maximum of 10 mm in thickness.

### 2.2 **Gloves**

The effective length of the spikes of the gloves: maximum 5 mm, measured in the axis.  
The fastening of individual spikes must guarantee that each spike must have an edge of at least 2 mm on three sides (refer to sketch 7).

### 2.3 **Safety Helmet**

Wearing a safety helmet is mandatory.  
Each athlete who takes part in a FIL competition must wear the official FIL sanctioned helmet.  
The visor is a component of the FIL safety helmet.

### 2.4 **Luge shoes, training/competition**

Every athlete participating in a FIL competition is required to wear the luge shoes approved by the FIL. These may not be modified.

Any kind of taping of the luge shoe is prohibited (except on damaged areas; however, this must be approved by the technical delegate).

Any stretching devices at, in, and outside of the body of the shoe are prohibited.

This is also valid for any attachments (for example, bandages, tapes, bindings and similar) for the overall area of the lower leg and foot.

However, an injured part can be protected by a bandage.

The necessity and application of the bandage are to be checked by the race physician and/or the technical delegate prior to the beginning of the race.

The luge shoes have to be freely purchasable from the respective manufacturers for all NFs.

New models must be inspected by the chairman of the Technical Commission and two Commission members selected by him and must be approved with the following conditions:

- ♦ One pair of luge shoes may not exceed the price of 150 EURO.  
The inflation rate can be added.
- ♦ Inspected and approved models will be left as sample in the FIL office with a production guarantee.
- ♦ Luge shoes must be manufactured in at least three sizes (37 to 45 European sizes).
- ♦ All the luge shoes used during competitions must be identical in form and material (not color) with the original shoes stored in the FIL office.

Time Frame:

A new model must be approved by July 15<sup>th</sup> by the Chairman and two members of the Technical Commission.

Until August 1<sup>st</sup>, all National Federations must be informed in writing by the FIL office on the new approved luge shoes.

Each National Federation is responsible for ordering the new models, but they can also be ordered through the FIL office.

When the order is made on time (August 31<sup>st</sup>), the new models must be available within two months.

2.5

**Race Suit**

It is mandatory to wear a race suit.

For racing suits, only textile fabrics may be used, the exterior surface of which must not be plasticized or otherwise sealed.

It has to be possible for each National Federation to buy the racing suit material or finished racing suits from all the respective manufacturers.

The race suit has to end in the middle of the foot.

If the race suit is fastened up over the heel, then the heel has to be a part of the suit.

If the race suit ends in the ankle-part, it must have a strap (refer to sketch 8).

It is forbidden to tape the race suit to the foot or with the socks.

Bootie covers are forbidden.

**Sketch 7**

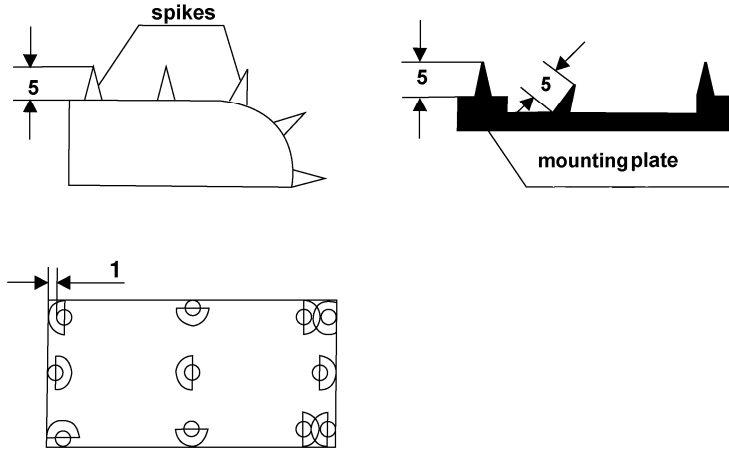

**Sketch 8**

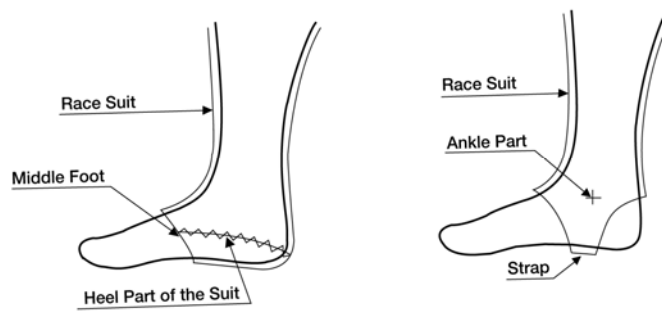

3. **Start Numbers**

- During FIL competitions, bibs are to be used for start numbers.
  - The start number has to appear on the chest and on the back.
  - The Executive Board and/or the event organizer can stipulate a second start number (for example: sticker).
  - Start number bibs must be elastic, sleeveless, and adhere closely to the upper body. They must not be changed.
  - Start number bibs must not be taped at the bottom edge; they may only be fastened at the height of the hip bone using two snap fasteners.
  - Taping of the start number bibs at the bottom edge with a maximum width of 6 cm is only allowed in the youth and junior classes.
  - Tucking in the start number bibs at the sides is only permitted if by doing so neither the number nor the inscriptions are affected.
  - It is forbidden to bind the shoulder straps together at the back.
  - With doubles, both athletes have to wear a start number bib.
- ◆ For Junior/Youth A World Cups and other international races for Junior and Youth classes, the event organizer may also use start number stickers if the quantity of bibs or the sizes are not available.  
This is not applicable to the Junior World Championships.

4. **Inspection Procedure**

All inspections of the sled must be carried out with appropriate expenditure of force and without excess use of force. The inspections must not lead to any damage to the sled.

**1. General Regulations**

During official training of the competition and race runs of any FIL competition, the following must be available:

- a) A race physician with knowledge of emergency care.  
During official training, the presence of a race physician may only be dismissed according to point 1.1a when a time frame for the emergency aid has been legally determined for the particular nation hosting an event and when its compliance is guaranteed.
- b) A minimum of one ambulance with one paramedic / ambulance officer.  
The ambulance must also be equipped with appropriate resuscitation equipment and be suitable/ capable of accessing all roads around and along the track; it must be placed in such a way that, in accordance with the local conditions, a fast pick up of the ill or injured athlete is possible from all areas of the track.
- c) A room exclusively used for first-aid treatment which is marked as such.

Should the race physician and/or the ambulance be medically required, the race or official training must be interrupted until their services according to the above-mentioned regulations are again guaranteed.

**2. Responsibilities**

The race physician and/or the ambulance crew are responsible for the primary care of injuries and illnesses of the athletes.

The race doctor has to certify in writing to the race director when there is a specific risk to life or health by the participation of an athlete as a result of an injury or illness or for any other medical reason (§ 4 point 1.1.5).

**3. Evacuation of injured athletes**

The event organizers must guarantee that injured persons can be transported away from any point along the entire length of the track without obstruction or difficulties.

**1. Applicability, Measuring Procedure**

**1.1 Applicability**

All these regulations are valid during FIL competitions as well as for media and PR activities and are applicable to athletes and officials.

**1.2 Measuring Procedure**

The size of a commercial marking or trademark is the surface within a line following the actual surrounding of the integrated marking.

If the trademark is integrated within an area of different color, the total area of the different color is to be measured.

The correctness of the measuring of the size of the trademark will be under the responsibility of the National Federations.

At FIL competitions, the race director, technical delegates and jury have the right to carry out control measurements at any time.

**2. Race Clothing**

Articles of clothing may carry manufacturers' identifications and/or trademarks of other sponsors.

The total surface of the trademarks together on the clothing (except head coverings, gloves and shoes) of one person shall not exceed 450 sq cm.

The complete surface can be divided into ten parts at the most.

The complete surface of a single part may not exceed 100 sq cm.

Trademarks of the same sponsor may not appear one above the other or one beside the other.

The National Federations may decide the placing of the trademarks.

The markings on the clothing will be measured when the clothing is not worn.

The respective National Federation is responsible for maintaining the advertising regulations.

The use of a manufacturer's specific graphic design - even though this design may also be registered - will not be counted as advertising spaces.

**3. Safety Helmet**

Athletes' safety helmets may display two (2) trademarks of the manufacturer with a maximum size of 15 sq cm, one each side, placed over the ears.

The advertising surface on the front of helmets may only be used by the FIL (60 sq cm).

It is permitted to wear a national emblem on the helmet (max. 30 sq cm) and also the name of the athlete (maximum twice, height of the writing maximum each 15 mm) at the back of the helmet without obstructing the official FIL advertising.

**4. Visor**

Visor straps have to conform to commercially available products. The width of the visor strap is limited to 4 cm.

**5. Caps, Headbands, and other Headgear**

Caps, headbands, and other headgear may each have a maximum of three (3) trademarks of the manufacturer and/or other sponsors, with a total surface of 90 sq cm maximum.

**6. Start Numbers**

Advertising inscriptions on start numbers are permitted.

The advertising surface must be smaller than the section bearing the start number.

During FIL Championships and World Cups of the General Class, the start number bibs provided by the FIL sponsor have to be worn during the official training.

7. **Luge Shoe**

Luge shoes may only show one manufacturer's trademark of 15 sq cm in size on each shoe. The trademarks can be divided in two parts.

8. **Gloves**

Gloves may only show one manufacturer's trademark on each glove. The marking can be divided into two parts. The total surface of the commercial marking per glove is limited to 15 sq cm.

9. **Racing Sled**

On the entire sled, in addition to the manufacturer's trademark, a maximum of five commercial markings may be displayed; maximum of two trademarks on the bottom of the sled. The size of the advertising surface on the bottom of the sled may not exceed 900 sq cm.

10. **Athlete**

Advertising with athletes is only allowed with permission of the National Federation responsible. Name, title, and picture of the athletes can only be used once for each advertisement.

11. **Forbidden Advertisement**

Provided there are no stricter national laws, following advertisement is prohibited:

1. on the athlete and sled: advertising for tobacco, illegal drugs or alcohol.  
Exception: advertising for non-alcoholic beer and, regarding athletes of age (18), advertising for products with an alcohol percentage of less than 10 %.
2. at the sports venue and on bibs: advertising for tobacco, illegal drugs or products with an alcohol percentage of more than 10 %. The FIL Executive Board can allow an exception of this prohibition following a request from the event organizer or the venue operator.
3. advertising conveying religious, racial or any other discrimination.

## **§ 8 Training, Weigh-in, Individual Supplemental Weights**

### **1. International Training Courses**

- 1.1 The NF that is holding a FIL World Championship (General Class) or Junior World Championship must provide an International Training Week before the staging of the championship in the respective season.  
At least 6 training days with a minimum of 4 training runs daily have to be offered to all interested National Federations.  
If the organizers do not adhere to this requirement, the Executive Board can reject the next application for an event.
- 1.2 Organizers hosting a FIL World Cup or Junior/Youth A World Cup must make available three (3) days of paid training (five (5) days for juniors/Youth A) to all teams prior to the event in that season.  
These days must be scheduled during the pre-season / preparation period and cannot be scheduled during the normal event paid training and official training schedule immediately prior to the event.  
A minimum of four (4) training runs each day must be offered.
- 1.3 The execution of international training sessions is strictly a matter of the National Federation (with exception of the OWG/YOG). The terms of these training sessions are to be set up by mutual agreement and under their own responsibility.

### **2. Paid Training**

- 2.1 Two days before the beginning of official training, organizers of FIL World Championships (General Class) and Junior World Championships are obligated to offer paid training.  
The track must be prepared before each group's training.  
Paid training is to be coordinated and supervised by the Sports Director/technical delegate.  
National Federations have to register for the paid training one week prior to the beginning of that training.  
Junior/Youth A World Cup:  
At least one day with a training session of at least three runs must be offered before the official Training.
- 2.2 If it is known in advance that there is not enough time for this paid training (as in the case of the "Drei-Bahnen-Tournee") then the organizers of the FIL competition must provide a minimum of 3 training days.  
This training must take place prior to the competition during a week when there is no World Cup or championship race scheduled.

### **3. Official Training**

#### **3.1 Systematic Training**

- 3.1.1 A training run on a shortened course (systematic training) has to be offered for singles and doubles.
- 3.1.2 If an athlete / doubles team does not take a systematic training run, he or she will be removed from that training run without substitution.
- 3.1.3 If the event organizer provides more than 3 training runs of paid training, there is no obligation to provide systematic training.

#### **3.2 Official Training Runs**

- 3.2.1 For FIL competitions, the organizers must hold free of charge at least five (5) training runs for singles and five (5) training runs for doubles.  
These training runs should include one (1) night run if there is to be a night run in the competition.



- These runs are to be timed and are to be conducted on the entire length of the course.
- 3.2.2 The doubles training is to be as follows:
- ♦ one systematic run as singles only if no paid training has previously taken place (at least 4 training runs)
  - ♦ two training runs as singles only if no paid training has previously taken place (at least 2 training runs)
  - ♦ one systematic run as doubles
- 3.2.3 During Junior/Youth A World Cups and Junior World Championships, seven (7) official training runs have to be provided free of charge.
- 3.2.4 The start order for the NFs for training will be drawn at the first team captain's meeting. Before the draw, it will be determined by the race director which nation in the drawn start order will begin the respective training run.
- 3.2.5 Two full days will be made available for official training by the organizers. There are no exceptions.
- 3.2.6 Reduction of the number of training runs  
If conditions prevail which make it impossible for the competitors to complete their stipulated training runs, i.e. warm wind, snowfall, etc., the race director in discussion with the technical delegates can interrupt training and set up a new training time.  
Regarding the number and completion of training runs, the race director will make a decision after conferring with the technical delegates.
- 3.2.7 Only the competitors eligible to participate in the respective competition may take part in the training (§ 3 point 8).
- 3.2.8 Doubles athletes may start from the men's or doubles start in singles training.
- 3.2.9 All unauthorized training by competitors on the track other than at the designated training times is forbidden.
- 3.2.10 In substantiated cases, with approval of the jury, the race director must allow competitors who have arrived late due to no fault of their own, to complete the minimum number of training runs if time allows them to do so.
- 3.2.11 In conjunction with the technical delegate, the race director is empowered to add additional official training runs.
- 3.2.12 During competitions that are held within a shorter period of time, the Sports Director in agreement with the race director makes the arrangements for training.  
It is to be guaranteed that all National Federations have the same conditions.
- 3.2.13 If the competition's planning results in a break of two or more days for athletes, an additional training run must be made available to them.
- 3.3 **Rules for World Cup training**
- 3.3.1. Number of training runs
- a) At the first World Cup of a season, all athletes are offered an equal number of training runs (at least 6 runs).
  - b) All participants in the preceding World Cup - 32 men, 24 women, and 24 doubles -- will receive 6 training runs on two or three training days at the next World Cup.
  - c) In addition to these 6 training runs, newcomers\* to a track will receive an extra run.  
\* Newcomers are athletes that have not yet participated in a FIL competition (WC/NC/FIL championships) in the General Class in their discipline on this track. For doubles, this applies if the team in the same composition has never before participated in a doubles competition in the General Class at this track)
  - d) If athletes according to the ranking specified above fail to appear at training, other athletes will not move up.
  - e) One day before World Cup training, all other registered athletes will receive an additional training session with 3 training runs for a total of 9 runs.
  - f) Systematic training can be held as part of the 6 or 9 runs offered.
- 3.3.2 Miscellaneous
- a) The NFs must register with event organizers using the FIL online registration tool.
  - b) The training is conducted in groups of approximately 23 to 28 participants.

- c) Within groups, each NF or training partnership will train successionaly with the start order men – women – doubles.
- d) The track must be prepared before each group (under the responsibility of the technical delegate with the chief of track).
- e) Training is scheduled and coordinated by the Sports Director.
- f) The start order for training is determined by the first team captains' meeting.
- g) If athletes should compete in both disciplines – men and doubles – the team captain must nominate the second training of these athletes in another group.
- h) Should athletes have a break of two days in the planning between the last training run and the first race run, an additional training run must be made available these athletes.
- i) Travel days are allowed for and fixed in the annual schedule.
- j) Event organizers must offer 5 training runs per registered sled free of charge.
- k) All other runs are offered against payment.

3.4 In paid training as well as in official training at FIL Championships and World Cup races, men, women and doubles of a country or of a training partnership must train within their groups (does not apply to JWC/YAWC).

3.5 **Timing**

When the respective start level is reached, the times are to be presented in writing with a start time and three intermediate times.

4. **Weigh-In**

4.1 The weigh-in (men with shorts and women with shirts, shorts, and underwear) takes place under the direction of the judge responsible for the weigh-in before the draw. Weigh-in of women should be conducted by a female judge.

The location and time of the weigh-in are to be announced at the first Team Captain's meeting. Upon confirmation of the events schedule, the FIL Executive Board, based on the proposal of the Technical Commission, will determine at which events a weigh-in will be carried out. (2 - 3 times per season).

For new athletes or for athletes with weight changes, a weigh-in check may be done at each competition.

- ♦ At the weigh-in, athletes competing in doubles event must notify the judges on who will be stepping on the scale with the sled during the competition.

4.2 A jury member or technical delegate must be present.

4.3 At least one heated room is to be provided by the organizers for the aforementioned weigh-in procedure.

4.4 At the draw, all participating National Federations receive a list of their athletes from the organizers on which the following weight information is noted: name, body weight, additional weight, weight of race clothing, and total weight permitted for the race.

5. **Individual Supplemental Weights**

5.1 Additional weights may be carried in singles' competitions for women, men, junior women and junior men, youth A women and men as well as in doubles, General Class, Junior Class, and Youth A Class.

5.1.1 The maximum amount of additional weight permitted is as follows:

- ♦ Women, Junior Women, Youth A Men 10 kg
- ♦ Men, Junior Men 13 kg
- ♦ Youth A Women 8 kg
- ♦ Doubles (General Class, Junior Class and Youth A Class) 10 kg

- 5.1.2 **Men** may use additional weight amounting to **100%** of the difference between body weight and a base weight of 90 kg.
- 5.1.3 **Women** may use additional weight amounting to **100%** of the difference between body weight and a base weight of 75 kg.
- 5.1.4 **Doubles athletes in General Class** may use additional weight amounting to **75%** of the difference between body weight and a base weight of 90 kg.  
Additional weight is not allowed if the body weight of the front person and back person together exceeds **180 kg**.  
If one of the partners weighs more than 90 kg, the weight exceeding the 90 kg mark will be added to the lighter partner.  
If there should still be a difference between the partner's weight and the 90 kg mark, the difference can be compensated according to the weight table.
- 5.1.5 **Junior men** may use additional weight amounting to **75%** of the difference between body weight and a base weight of 90 kg.
- 5.1.6 **Junior women** may use additional weight amounting to **75%** of the difference between body weight and a base weight of 75 kg.
- 5.1.7 **Youth A men** may use additional weight amounting to **75%** of the difference between body weight and a base weight of 75 kg.
- 5.1.8 **Youth A women** may use additional weight amounting to **50%** of the difference between body weight and a base weight of 70 kg.
- 5.1.9 **Doubles athletes in Junior Class** may use additional weight amounting to **50%** of the difference between body weight and a base weight of 90 kg.  
Additional weight is not allowed if the body weight of the front person and back person together exceeds **180 kg**.  
If one of the partners weighs more than 90 kg, the weight exceeding the 90 kg mark will be added to the lighter partner.  
If there should still be a difference between the partner's weight and the 90 kg mark, the difference can be compensated according to the weight table.
- 5.1.10 **Youth A doubles** athletes may use additional weight amounting to **50%** of the difference between body weight and a base weight of 75 kg.  
Additional weight is not allowed if the body weight of the front person and back person together exceeds **150 kg**.  
If one of the partners weighs more than 75 kg, the weight exceeding the 75 kg mark will be added to the lighter partner.  
If there should still be a difference between the partner's weight and the 75 kg mark, the difference can be compensated according to the weight table.
- 5.1.11 The additional weight must be worn by each competitor individually.
- 5.2 The weight of the race clothing may amount to 4 kg and may be compensated for in all disciplines.
- 5.3 Under no circumstances may additional weight be attached to the sled.  
Additional weight must be carried on the body on the torso and/or thigh and must not be able to shift freely.  
It should be attached and distributed in such a manner that bruises or other injuries will not occur.  
Additional weight, including fixings and body protection, may not exceed a maximum thickness of 20 mm except on the back of the competitor where it can be 30 mm thick in an area which is 25 cm wide and centered on the axis of the body.

**§ 9 Race Preparation, Entries, Entry Fee, Draw**

**1. Entries**

- 1.1 Each NF has to submit entries for its competitors, including additional starters, to the organizers using the FIL online registration form by the deadline appearing in the invitation to the race.
- 1.2 Continental Championships (Race in Race WC/JWC)  
NFs which have more athletes competing than are eligible for participation in FIL Championships (§ 3 point 3), must submit the names of the athletes for the championship rankings to the race director in writing before the draw.

**2. Entry Fee**

Entry fees for all athletes must be paid to the official designated by the NF prior to the start of the draw who then issues a receipt.  
Entry fees remain the property of the sponsoring NF.  
For all FIL competitions, the amount of the entry fee for each competitor in each discipline will be determined in Euro by the FIL Executive Board.  
Entry fees paid for competitors will not be refunded.

**3. Draw**

- 3.1 Time and location of the draw are stated in the invitation to the competition.
- 3.2 The race director is the chairperson of the draw.
  - The draw takes place after completion of the training.
  - The draw by name and/or NFs takes place after the announcement of the number.
  - The draw by number after the announcing of the name is allowed if required due to the creation of a computerized start list.

- 3.3 During the draw, the jury must be present.

**3.4 FIL World Championships in General Class**

Only the start order for the seeded groups will be an open draw.  
- Men: 1 - 7 + 8 - 15  
- Women: 1 - 12  
- Doubles: 1 - 12  
The rest of the start order will result from the preliminary run (§ 3 point 6.1).

**3.5 World Cup**

Only the start order for the seeded groups will be an open draw.  
- Men: 1 - 7 + 8 - 15  
- Women: 1 - 12  
- Doubles: 1 - 12  
The rest of the start order will result from the placement of the qualification (§ 3 point 6.2.6).

**3.6 Junior World Championships**

- The seeded group A (1 - 12) will be drawn by name / Junior World Championships (§ 3, 6.3.1.3)
- The rest of the start order is determined by the placement in the preliminary run (§ 3, 6.3.1.4).

**Junior World Cup**

- No draw for the seeded group A (draw only upon a default in the Grid Race)
- The start numbers are assigned according to the placement in the Grid Race (§ 3 point 6.3)

**Youth A World Cup**

- The seeded group A (1 - 12) will be drawn by name.
- There is no draw for the group B. The start order results from the overall Youth A World Cup ranking (§ 3 point 5.4).
- A necessary draw for athletes with the same number of points will be done by the jury.
- The remaining group will be drawn.

- 3.7 For the doubles, the names of the team members must be known before the draw.
- 3.8 Names entered for the doubles competition are binding for the duration of the discipline and may not be changed during the race.
- 3.9 During the draw, the times of the start order for the competition have to be announced.
- 3.10 The outcome of the draw (start list) and start order are to be immediately announced publicly. A copy of the start list is to be given to each team captain.
- 3.11 Exchanging of start numbers is not permitted.

**1. Start**

**1.1 Start Rules**

In all disciplines, starting from a start ramp is required.

The start time and start order for the athletes are to be clearly displayed at the start and at the finish.

The athletes are responsible for informing themselves promptly of the order and their respective start times.

During the OWG, FIL Championships and World Cup races, 1-3 forerunners have to start per race run.

During Junior/Youth A World Cup races, forerunners should also be available.

**1.2 Call to Start**

The beginning of each heat must be announced over the loudspeaker system along the track 15, 10, 5, 2 and 1 minutes prior to the first starter.

This applies to all training and competition runs of FIL competitions.

The call to start must take place in the described countdown mode in order to ensure that all persons present at the track are reliably informed on the beginning of the runs.

For competitions runs, the call to the start area follows the checking of the sled and athlete in the start area.

The athlete must go to the start area within two (2) minutes of being called.

Only one (1) person is permitted to assist a competitor in the start ramp area.

**1.3 Command to Start**

The signal to start has to be carried out acoustically and optically by a time display which is clearly visible to the athlete.

- ♦ Start signal lights and start clocks must be installed at all start heights.
- ♦ The track is closed to all athletes when the light is red. The athlete at the start may only start if the green light is visible.
- ♦ The start must take place within thirty (30) seconds after the "Track is Clear" notice for singles and within 45 seconds after the "Track is Clear" notice for doubles.
- ♦ The start is valid if the athlete has left the start handles within this time with a push and has put the sled in motion.
- ♦ A flying start is not allowed.
- ♦ When an interruption occurs during a competition (with the exception of a determined sweeping interval in case of snowfall), the starter must give the next athlete two (2) minutes preparation time before the signal "Track is Clear" is given.

**1.4 Start Intervals**

Only one sled may be on the run at any one time; exception: Team Relay competition (§ 3 point 6.4).

The starter may allow the athlete to start only if the "Track is clear" statement has been relayed to the start leader from the finish.

**1.5 Start Assistance**

Assistance by others in accelerating is forbidden.

**2. Inspections at the Start**

At the start, the following checks will be made:

- a) Temperature of the blades - will also be checked on forerunners, he/she may not start if blades are too warm.
- b) Fastening of the start number.
- c) Weight checks of the athlete and sled  
(During junior/youth races, weight checks of the sled and athlete can also be done at the finish for organizational reasons).

d) The empty spaces / spaces to be measured between runner and blade  
The results of the examinations at the start are to be noted in the official records.

All inspections of the sled must be carried out with appropriate expenditure of force and without excess use of force. The inspections must not lead to any damage to the sled.

**2.1 Weight checks of athlete and sled**

2.1.1 Every athlete steps on the scale at the start with his sled (in the case of doubles, one athlete with the sled, the other athlete without the sled (§ 8 point 4.1)).

The sum of the body weight, weight of the race clothing and additional weight is not to be exceeded. The results are to be entered in a list.

2.1.2 The weighing procedure at the start will be supervised by a technical delegate.

2.1.3 The scale must reflect incremental units of 100 g.

2.1.4 A gauged scale must be installed for the pre-competition weigh-in for the athletes under supervision of a judge both at the start (women's, men's, and doubles' starts) and at the finish. These scales must be placed at the disposal of the athletes 1 ½ hours before the beginning of the race.

Control weights (5 x 20 kg) must be available for calibrating the scales (start, finish, changing room).

At the Winter Olympic Games and FIL Championships, scales must be set up under the same prerequisites in both start areas.

**2.2 Measurement of the temperature of the blades**

2.2.1 An official temperature check of the blades, using an approved digital device with a measuring accuracy of 1/10 degree, is to be conducted by the official involved with blade measurement between the call to start and start preparation. Results are to be entered in the official records in 1/10 degrees.

2.2.2 The temperature of the steels will be taken in four locations: The temperature of one steel will be measured at the rear bridge attachment, and of the opposing steel at the front bridge attachment. The temperature of each steel will also be measured once each at a random location between the bridge attachments.

2.2.3 At the start, a control blade 50 cm long, corresponding to the profile of a blade, is to be set up as permanent equipment attached in a location sheltered from the sun, and is to be used as a basis for temperature measurement. The control steel may not be placed in an exposed area and must be protected from drafts.

The temperature of the control blade is to be taken 30 minutes before the start and is to be repeated every 15 minutes from that time.

The results of these temperature checks are to be posted in 1/10 degrees on a notice board that is visible to everyone.

The temperature of the blades on each athlete's sled may not be greater than 5°C above the control temperature.

The control temperature is established from the control blade located at a height of 1/2 to 1 meter from the ground.

Should the temperature of the control blade fall below -5°C, the blade temperature may continue to be 0°C.

2.2.4 For measuring the temperature at the start and finish, three official identical temperature gauges including sensors are to be made available.

- At the start, one gauge is used by the judge for the official measurements, one gauge is available for control measurements.

- Official measurement and control measurement should be recognizable as such without any doubt and both gauges are to be marked differently.

- The first gauge is used in the start room for the official measuring. Only two sleds at a time can be brought up for the official measuring. Each sled will only be measured once appropriately.

- The second gauge is used for control measurements.

- The third gauge is available at the finish for control measurements.

- All gauges may only be used by the judge assigned to it and may not be given to someone else.

- 2.2.5 After the beginning of the official measurement, the sled must not be removed from the designated start area. This also pertains if there is a delay in starting.
- 2.2.6 After examination in the start area, the sled must neither be exchanged nor the blades warmed. After examination at the start up until the control at finish, the sled may neither be exchanged nor modified.
- 2.2.7 Every sled preparation to improve the gliding process is not allowed after the official inspections at the start.

2.3 **Inspection of the start number fastening**  
The start number fastening is to be checked visually.

2.4 **Inspection of race equipment**  
If the zipper of a race shoe breaks after the official controls at the start, the race shoes may be exchanged. The athlete, however, must start within the given start period - no extra time is granted. The change must be reported to the TD in order for it to be inspected at the finish.

2.5 **Start under protest**  
A start under protest has to be granted

3. **Finish**

3.1 The finish and with it the end of the training or evaluated run is determined by the finish light barrier. Either the athlete or the sled may trigger the finish light barrier, the athlete/athlete pair must be in contact with the sled.

3.2 In the finish area, the Sports Director must arrange a zone where the athlete must be able to leave the track without any help.  
An escort in this zone is not allowed.  
This is valid for the OWG, FIL Championships and World Cups in the General Class.

3.3 Under the responsibility of the organizers of Championships and World Cups, a time display has to be installed at the end of the outrun where the times of each run and the current ranking of the athlete will be shown sufficiently long enough to be seen by the athletes.

4. **Inspections at the Finish**

4.1 At the finish, the following inspections take place: the weighing of additional weight, sled and racing clothes, the checking of the temperature of the runners as well as weight and measurement of the sled and seat (pod) of those athletes who draw the red balls or get the red signal of the random generator. Each athlete draws a ball or pushes the random generator. For doubles, only one athlete draws a ball (random generator) for the inspection; however both athletes must go to the inspection with the sled.

- ♦ Singles      First Run,                  6 drawn athletes, 3 of them from the seeded group
- Second Run,                no draw
- ♦ Doubles     First Run,                  3 drawn Doubles
- Second Run,                no draw

The draw will be carried out upon the arrival of the athlete at the finish area under the supervision of a jury member or technical delegate.

The results of the examination at the finish are to be noted in the official records.

- 4.1.1 During the measuring process, the sled must be lying on the table on its own without the support of an official (§ 5 point 1.9).
- 4.1.2 When the pod is being inspected, the athlete must lay down on the sled in the sliding position. In doubles, the front man must fasten his seat strap (§ 5 point 1.9).



- 4.2 One of the three lots from the seeded group will be marked in an additional way.  
After the first run, the sled of the athlete who has drawn this lot will be marked by the technical delegate and inspected after the second run in accordance with § 5 points 1.11 and 1.12.  
- At the OWG the drawn sled is marked after the first run or third run and is inspected for compliance with §5, 1.11 and 1.12 after the last run on the current day.
- Under supervision of the technical delegate, a member of the team will dismantle a runner from the sled of the drawn athlete and the technical delegate will inspect the connection of bridges in the runners.  
If in the second or fourth run, this athlete uses another sled than in the first or third run, he or she must also present the marked sled from his or her first or third run, so that it can be inspected.
- ♦ Regarding junior competitions, the inspections according to § 10 point 4.2 will be carried out at the World Junior Championships and Junior World Cups. Random check will be carried out by the controls in the Youth A.
- 4.2.1 During the OWG and FIL Championships, the sled of the first three places in all disciplines will be controlled after the last run.
- 4.2.2 During the second as well as the fourth run of the FIL Championships and Olympic Winter Games the blade temperature of the best 10 athletes/double teams from the first, as well as the third run will be controlled at the finish.
- 4.3 The inspection of racing equipment and sled may take place, point by point, among additional athletes by order of the technical delegate.  
The type and extent of the drawn and additional inspections are subject to the judgment of the TD.
- 4.4 Pressure measurement steel/runner, runner, connector**  
The pressure is measured by the TD with a mechanical device on the parts mentioned above and spots freely chosen. The Executive Board annually decides on the pressure (Nm) to be used on the inspection device and the resulting maximum measurement value.
- 4.5 Inspection of the sled pod**  
At the first World Cup event of every season, all sleds are to be presented to the TD for the measuring of the pod. In the event of a positive evaluation, an official FIL sticker is put onto the sled.  
If an athlete makes changes to the pod during the season or enters the World Cup series at a later date, he has the weekly opportunity to present the sled for technical pre-inspection.
- 5. General Rules**
- 5.1 Principle Rule**
- During all FIL competitions, the athlete must travel on his/her sled from the start to the finish in a seated or reclined position.
  - If an athlete crashes, he/she must always be in contact with the sled. A crash is not grounds for disqualification.
  - If a competitor loses any item during a run with the exception of visors, that athlete can be disqualified if the intention to disadvantage subsequent athletes is clear.
- 5.2 Passing the finish line**  
If an athlete crashes near the finish, then he/she must reach the finish (in doubles, both athletes) in contact with his/her/their sled and trigger the finish line barrier. Pushing, paddling or walking with the sled in order to reach the finish light barrier is not permitted and will lead to a disqualification.
- 5.3 Modification and exchange of the sled**  
The exchange of, or modifications to, the sled during a discipline are permitted in accordance with the rules.

- 5.4 **Workshop**  
A suitable workshop area is to be placed at the disposal of the athletes by the organizers so that necessary work may be completed on their sleds.
- 5.5 **The entire length of the track is to be checked.**  
At OWG, FIL Championships, and World Cup races, anemometers must be installed at the exposed areas on all tracks.  
The Technical Commission of the FIL decides on the location of these.  
If wind speeds of more than 35 km/h (9.8 m/sec) are measured, the technical delegate and the race director decide upon further training and/or racing procedures.
- 5.6 **Track alterations during the execution of a discipline**  
If weather conditions, such as snow, thaw, etc. create unequal conditions for individual athletes during a race, organizers must provide a readily available work crew.  
While the forerunners are starting, the technical delegate determines the intervals of the sweeping as follows:
- ◆ sweeping interval (for example after every third athlete)
  - ◆ sweeping time (for example 1 minute)
  - ◆ if there is a break during a run, the track is swept until the next athlete starts (break time = sweeping time)
  - ◆ during the last run, the distribution of the sweeping intervals starts with the best rank
  - ◆ the race director is responsible for the entire sweeping intervals. The team captains have to be informed.
- Any conscious change of track conditions during a race is forbidden.
- 5.7 **Quality of the track**  
During final training and competition of each discipline (can be one or more runs), the following conditions must be adhered to:
- ◆ Change to the ice profile may no longer be done (only damaged areas can be repaired).
  - ◆ The ice must be superbly prepared (racing condition).
  - ◆ The ice temperature and water spray temperature must be kept as constant as possible.
  - ◆ There must be sweeping intervals during snow fall.
- This arrangement must be determined by the technical delegate and race director.
- 5.7.1 Fundamentally, sun shades must be open during official training and competition. If necessary, sun shades may be shut after consultation with the TD.
- 5.8 The decision whether the track is prepared prior to a run or not will be made by the technical delegate together with the race director.
- 5.9 Competitions may be held in extreme weather conditions with a temperature as low as minus 25°C.
- 5.10 The Executive Board can make exceptions regarding the maximum distance between the start and finish lines for FIL competitions.
- 5.11 At FIL competitions, the competition stretch can be shortened by a jury decision under special circumstances.
- 5.12 **Transportation of sleds and athletes**  
Along the track, there must be paths or other facilities which make it possible for the athletes to travel with their sleds from the finish to their respective starts without great difficulty. The transportation should be available on time before and after the training or competition.  
It is necessary to provide adequate opportunities for parking in the start and/or finish areas.

## 6. **Timing**

### 6.1 **Timing Equipment**

Timing equipment with automatic and printing capabilities is required and must operate with at least one (1) start time, three (3) intermediate times and the finish time with an accuracy of 1,000th of a second.

The official start and finish light barriers have to be marked during training and competition in color across the entire bottom and sides of the track.

All other openings necessary for installing light barriers at the start and finish areas are to be covered.

The installation of additional timing equipment by third parties is forbidden.

#### 6.1.1 **Timing Equipment**

- a) Two independent timing systems, each consisting of at least one time measuring device, complete set of light beams and independent power supply, must be available and in operation during a competition (A and B systems).
- b) The A system comprises all light beams for start, start time, three intermediate times and finish time for each start height as required by the rules.
- c) The B system comprises at least the start and finish light beams for each start height to record the run time.
- d) The time of day of both timing systems (A and B systems) must be synchronized and have an accuracy of 1,000th of a second.
- e) Two evaluation and control computers for the timing system must be available and in operation during a competition.
- f) The times measured by both timing systems must be recorded in both evaluation and control computers of the timing system.
- g) In case of failure of the A system it must be possible to switch to the B system without time delay. After this, the times measured by the B system will be used for the continuation of the competition. The times recorded by the A system up to this point will remain valid.
- h) In case of failure of the evaluation and control computer currently operating, it must be possible to switch to the second computer for controlling the timing system within a short time frame. The ranking valid up to this point is to be saved.
- i) A check list will be issued detailing the switching between the two timing systems and the two control computers.
- j) Independently from the computer, the light beam times recorded by each timing system must be printed as daytimes on a corresponding timeline printer.
- k) For external service providers an online data interface must be available through which they can obtain the measured light beam times (e. g. when TV graphics are required)
- l) Uninterrupted power supply must be available for the timing system (time measuring devices and control computers) securing that at least the time of the current sled to the finish is recorded. The power supply of the light beams of the A and B systems must be independent from each other.
- m) Start light signals must be available at all official start heights.

### 6.2 **Preparation**

The timing equipment must be tested and be ready for use at least one (1) hour before the beginning of each discipline.

### 6.3 **Difficulties**

If a problem occurs with the timing equipment, the timer responsible must immediately inform the race director; the race director may interrupt the race as long as it takes to guarantee proper timing. The athletes who were affected by the timing failure must repeat their runs at the latest within 30 minutes. The race director will decide on the exact starting time.

This also applies during training.

- 6.4 **Breakdown of timing equipment**  
If there is a prolonged breakdown of the electronic timing equipment during a heat, the heat may be annulled by the race director with the consent of the technical delegates.
- 6.5 **Finish House**  
Team officials and competitors are not permitted in the area in which the recording of time is performed during the duration of the competition.
- 6.6 **Maintenance of the timing equipment**
- a) For each season the timing equipment must be maintained by a professional company.
  - b) A maintenance report will be issued specifying the operations carried out during the maintenance.
  - c) Records must be kept of all existing deficiencies which cannot be corrected immediately through the regular maintenance activities (e. g. computer damage).
  - d) In the maintenance report it must be confirmed that the timing equipment is ready for use.
  - e) The track operator must submit the maintenance report to the FIL Office prior to the first international competition.
7. **Results**
- 7.1 The official results are the total sum of the times recorded by the athletes in each individual heat.
- 7.2 If two or more athletes record the same time for a run, they are awarded the same place.
- 7.3 The first and family name (last name) and start number of athletes who dropped out or who were disqualified are to be entered in the results lists with the times achieved up to that point.  
Under "dropped out ", all applicable athletes are classified as:
- ◆ Did not start (DNS) e.g. sickness, injury
  - ◆ Did not finish (DNF) e.g. did not finish due to a crash.
- 7.4 The official results list is to be signed by the race director and the chairperson of the jury.  
The names of the jury members and of the technical delegates are to be listed.  
The full names of all participants are to be entered on the results list.
- 7.5 At the end of the competition, the official results lists or CD are to be distributed to each National Federation participating in the competition.  
One original copy must be sent to the FIL office immediately after the competition.
- 7.6 **Results and timing lists as evidence**  
The official times for each athlete are to be immediately recorded in writing.  
All documentary evidence is to be used as a basis for checking and for possible protests.  
All documentary evidence is to be kept by the organizer for a period of one year after the end of a competition.

## **§ 11 Disqualification, Protests**

### **1. Violation of Rules**

1.1 A disqualification can be declared by the race director if athletes or teams have violated regulations in the IRO and if the violation is detected between the beginning of training and the end of the competition including all inspections required by the IRO (§ 4 point 1.1.7).

#### **1.2 Procedure during competition**

1.2.1 The TD, the start or finish leader has to immediately inform the race director if a violation has been determined. Participating jury members or TD are also to be informed.

1.2.2 Items or respective pieces of evidence are to be submitted to the race director by the judge, jury member or by the respective TD.

1.2.3 Upon reviewing circumstances in the presence of a jury member or TD, the race director can declare a disqualification.

1.2.4 The team (coach) affected must be immediately informed about this. The athlete is to be informed should there be no coach on site.

1.2.5 A rule violation must be declared to the team or athlete affected at the latest 10 minutes after the end of the respective competition run.

1.2.6 The piece of evidence must be provided to the TD, start or finish leader in order to clarify the situation.

1.2.7 In case of a disqualification, a report on the violation of the rules is to be given to the team captain or athlete affected.

1.2.8 The athlete has the possibility at the start to take his/her run under protest.

### **2. Protests**

#### **2.1 Reason for a Protest**

If an athlete or a team believes himself/herself to be at a disadvantage due to factors which have occurred during official training, a race run or for another reason during a competition, the team captain/athlete has the right to protest.

A camera flash does not provide a reason for protest.

#### **2.2 Procedure**

2.2.1 Protests must be made in writing and must be dated and signed by the team captain or the team captain's representative.

2.2.2 The protest must be given to a jury member.

2.2.3 A protest fee of 50 Euros is to be paid when the protest is submitted.

2.2.4 In case of a disqualification, the written protest must be submitted within 10 minutes after receipt of the report according to § 11 point 1.2.7. In all other cases, it must be submitted 10 minutes after completing the official training, the competition, or other protest reasons.

#### **2.3 Settlement**

2.3.1 The jury decides on all protests.

2.3.2 Concerning a protest, the jury must meet within one (1) hour of the submission of the protest.

2.3.3 If the reason for the protest is first known after the ten minutes (noted in point 2.2.4), the jury must deal with the protest and observe the final deadline for submission of the protest which is the conclusion of the competition (awards ceremony).

2.3.4 The jury may call in all persons and items connected with the protest on the spot to help clarify the circumstances.

2.3.5 In the case of a protest, the jury has to decide whether pieces of evidence (for example, films, pictures, video records, etc.) may be presented. However, this material is only used to help in making a decision.

2.3.6 The protest fee is returned in its entirety if the protest is decided in favor of the protesting party.

2.3.7 The team captain/athlete must be informed in writing if a protest is rejected.

2.3.8 If the protest is denied, the protest fee is forfeited and is granted to the organizers of the event. The protest fee must be given to the race director.

- 2.3.9 The decision of the jury in all protests is final. It may only be appealed against in accordance with the FIL Law and Procedure Regulations.
- 2.3.10 All decisions made during a FIL competition by the race director, TD or jury member are only valid for this competition.
- 2.3.11 If violations of the regulations in the IRO are discovered after the conclusion of the competition, including all inspections required by the IRO, then the FIL Executive Board will make the decision in this case.

**1. Titles for World Championships**

The invitation to the race notes the titles to be awarded at the FIL Championships. These are to be awarded to the winners in the following disciplines:

- 1.1 Men's Singles with the title:  
"World Champion in Men's Singles"
- 1.2 Women's Singles with the title:  
"World Champion in Women's Singles"
- 1.3 Doubles with the title:  
"World Champion in Doubles"  
Both competitors receive the same titles and same honors.
- 1.4 Team-Relay competition with the title:  
"Team Relay World Champion"
- 1.5 The same titles and honors are used for the Junior World Championships, the title for the Team competition: "Team World Champion"

**2. Titles for Continental Championships**

The titles for Continental Championships are to be bestowed with the same name as the corresponding competition.

**3. Awarding of titles in case of a reduction of runs**

If the number of runs in a discipline is reduced, titles are only awarded if all athletes participate in at least one run.

**4. Certificates**

- 4.1 The certificate is an individual and written confirmation of participation in a championship. The following must be clearly noted on the certificate:

- ♦ Name of the sponsoring NF
- ♦ Type of championship and the discipline in which the competitor participated
- ♦ Name of the athlete
- ♦ Level reached by the competitor in the final rankings
- ♦ Signatures of the FIL representative, chairperson of the jury and race director
- ♦ Location and dates of the event

- 4.2 Each competitor and official participating in a championship must receive a certificate.

**5. Medals**

- 5.1 For FIL Championships, World Cups, Nations Cups, JWC, YAWC, Team Relay World Cups, and Sprint World Cup, medals are awarded for places 1 to 3.

- 5.2 The medals are provided as follows:

- ♦ By the FIL:  
FIL-World Championships (General Class) and Junior World Championships,  
Overall World Cup in General Class / Junior Class / Youth A Class and Team Relay.
- ♦ By the organizers: Continental Championships, individual World Cup, Team Relay, Sprint World Cup, Junior/Youth A World Cup and Nations Cup.

6. **Pins for Competitors and Officials**

It is the obligation of the NF staging FIL Championships to give pins or badges as gifts at no cost to the athletes and officials.

7. **Gifts of Honor and Mementos**

The organizers are permitted to give participants in FIL Championships and FIL competitions gifts of honor and mementos.

8. **Awards Ceremony and Conclusion of the Event**

8.1 **Procedure**

The organizers must hold the awards ceremony for the champions as well as for the second and third place finishers in each discipline immediately after the competition in the finish area as follows:

- ♦ At the awards ceremony of all FIL competitions (FIL Championships, WC, TWC, SWC, JWC and YAWC), flags of the National Federations of the champions and the second and third place finishers must be raised.  
During the ceremony, the champion's national anthem must be played.
- ♦ If there are less than three ranked athletes in one discipline, this awards ceremony will not be staged.
- ♦ The staging of the official awards ceremony together with the flower ceremony is allowed.
- ♦ In the event of a tie for first place, the anthems of both competitors will be played in alphabetical order of family names.
- ♦ In the case of a tie in doubles, the family name of the front man is used.
- ♦ In the event of a tie, both flags will be raised.
- ♦ The same procedure may take place at all international competitions.
- ♦ The medals are presented to the top three finishers by the FIL representative. By the representative's absence, the chairperson of the jury awards them in a festive ceremony.

8.2 **Awards Ceremony for Overall World Cup and Team Relay World Cup**

The champions as well as the athletes placed second and third in the overall World Cup in the men's, women's, and doubles' disciplines receive World Cup trophies provided by the FIL.

The top three ranked athletes in each discipline, as per total scoring, receive medals in gold, silver, and bronze.

The World Cup trophies and medals will be awarded at the awards ceremony of the last competition (World Cup final).

8.3 **Awards Ceremony for the Overall Junior and Youth A World Cup**

The overall champions of the Junior and Youth A World Cups receive trophies provided by the FIL.

The top three ranked athletes in each discipline, as per total scoring, receive medals in gold, silver, and bronze.

The trophies and medals will be awarded at the respective last competition (final competition).

8.4 **Ceremony FIL World Championships**

At the conclusion of an awards ceremony at FIL Championships, the FIL President or representative presents the FIL flag in a ceremonious manner to the representative of the NF which will stage the next FIL Championships.



## § 13 Concluding Regulations

1. The IRO is available in German and English.  
In case of unclarity or contradictions, the German text is binding.  
All event organizers are required to provide a translator at all team captains meetings for German and English.  
Furthermore, translator(s) must be on-site during the race day to assist with translation in the event an emergency, protest, or other matter surfaces.
2. Resolutions regarding amendments and additions to the IRO can only be made by an ordinary Congress and require a simple majority as long as the priority regulations of the FIL statutes do not state otherwise.  
Urgency motions to change the IRO are only permitted in adherence to the FIL statutes.
3. In substantiated cases for exceptions, changes in the IRO may be decided by the FIL Executive Board upon proposal by the appropriate expert commission.  
They will be presented for ratification at the next FIL Congress.  
The same is valid in case of controversial interpretations, contradictions and omissions in the regulations of the IRO.
4. Changes and additions to the IRO become valid with the beginning of the following sport year on July 1st. Executive decisions will become valid as of the date agreed on.
5. This edition of the IRO becomes valid from July 1, 2014 onwards.  
At the same time, the former regulations of the IRO become invalid.

## **Supplement 1**

### **Regulation for Artificial Luge Tracks**

#### **1. General**

All championships and competitions awarded by the FIL are staged on tracks which are recognized by the FIL and which are officially commissioned.

#### **2. Definition**

- 2.1 Artificial luge tracks are luge tracks which have been specially constructed for the sport of luge by means of specific construction measures.  
A difference is made between artificial luge tracks with or without refrigeration system.
- 2.2 Combined bobsleigh and luge tracks are tracks which have been specially constructed for the sport of bobsleigh and luge by means of specific construction measures.  
A difference is made between tracks with or without refrigeration system.
- 2.3 Shortened tracks are artificial luge tracks with or without a refrigeration system with a minimum length of 400 m.  
They are suitable for international competitions.

#### **3. Regulations for the Construction of Tracks**

##### **3.1 Length of the track**

The minimum length of the track between the start and finish lines must be at least 1,000 m for men's singles and at least 800 m for women's singles, doubles and juniors.  
As a general rule the maximum length between the start and finish lines for men's singles must not exceed 1350 m. Necessary exceptions due to topography must be approved by the Executive Board.

- 3.1.1 The gradient of the track should be designed in a way that a speed of approx. 80 km/h is reached approx. 250 m after the start. The average gradient of a track from the men's start to the low point should not exceed 10%. The average gradient of the second half of the track should not exceed 8%. The calculated maximum speed must not exceed 135 km/h. The technically difficult track elements (labyrinth, left-left or right-right combinations) should be incorporated in the first two thirds of the track.

##### **3.2 Finish outrun**

The gradient of the outrun must not exceed 20% and must give the athletes the possibility for an exit along one side.  
The length must be calculated so that a sled, without braking, will not exceed 40 km per hour at the end of the outrun.  
The sled must be able to travel further unhindered.  
Should a gentle angle or a curve be necessary in the outrun area, this must not be considered as a braking area.

##### **3.3 Shortened tracks**

- 3.3.1 Minimum length 400 m  
Track components: 1 left curve, 1 right curve, 1 labyrinth, 1 straightaway.
- 3.3.2 If one wishes to build a shortened track into a full length track according to section 3.1, the shortened section should be the upper part of the final track.  
The top speeds on a shortened track must not exceed 80 km/h.

- 3.4 **Start facilities**  
 For men, women, doubles, juniors and youth events, the track must be equipped with all the necessary starting structures to guarantee normal execution in all disciplines.  
 During FIL competitions, it must be possible to close off the starting zone.  
 The individual components of the start facility are: a horizontal iced surface on which the sitting position on the sled may be taken by the athlete.  
 Length of the horizontal iced surface to the start handles: at least 2000 mm.  
 Length of the horizontal iced surface from the start handles to the beginning of the descent: 500 mm (refer to sketch I).  
 Two start handles adjustable in height on either side of the start area which may be used by the athletes to increase the speed of their start (refer to sketch II).  
 From the ice to the upper edge of the handles at an equal height: 230 mm - 250 mm.  
 Inside distance between the two handles: 700 mm.  
 Length of the handle: at least 150 mm.  
 Diameter of the handle: 27 mm.  
 The surface of the handle must be grooved.  
 The construction of the start handle should be so solid that it cannot be bent upon the athlete's pull off.  
 The start light barrier must be installed between 5 m and 10 m after the start handles. The start time (from start light barrier to next light barrier) should exceed 3 seconds; if this is not possible, it should be taken immediately after the first curve. Light barriers must be installed in a height of 300 mm above the bottom of the track measured from the concrete. The height must be between 20 cm and 25 cm on the iced track.
- 3.4.1. The start ramp should have a gradient of 20-25% and a length of min. 10m and max. 30 m. The entry angle should not exceed 8° to the track axis.
- 3.4.2. Regular start ramps must be included for men's, women's, doubles, Juniors, and Youth A. The locations are set by the Track Construction Commission in the preliminary planning phase.  
 Two additional short start facilities should be provided for youths and tourists.
- 3.5 **Safety regulations**  
 The track layout and components such as curves, walls, bridges, tunnels, transportation set-ups, etc. as well as all facilities originally belonging to the track must be provided in such a way, that the safety of the user is guaranteed to the greatest extent possible.  
 If the safety regulations on a track are neglected so that the participants in FIL competitions are exposed to atypical danger to their health, the track may only be released by the technical delegate for further use if these deficiencies are remedied.  
 If the steps taken are not sufficient in order to guarantee that the internationally recognized safety standards are followed during a competition, the jury, in agreement with the technical delegates is empowered to shorten the track.
- 3.6 **Commissioning**  
 The FIL Executive Board decides on official recognition and approval of an artificial luge track for OWG, FIL Championships and FIL competitions after the following criteria have been fulfilled:
- ◆ Examination of the project documentation,
  - ◆ Inspection during summer construction,
  - ◆ Release of the project through the designers and construction engineers,
  - ◆ Release of the track for the test is done by at least two members of the Track Construction Commission,
  - ◆ The test for the homologation takes at least four days with two test sessions per day. (Approved at the 59<sup>th</sup> FIL Congress 2011 in Berlin),
  - ◆ The test must be carried out by at least 3 men and 3 women in singles and 3 doubles from different nations. The participating athletes are suggested by the FIL Executive Board,
  - ◆ Upon a successful test, the track will be commissioned by the Executive Board of the FIL,
  - ◆ The final commissioning of the entire track facility will be issued according to the criteria in the Book of Requirements.

The expenses are assumed by the track owner.

The owners are to receive written information concerning the commissioning of an artificial luge track within one (1) month after a positive resolution by the FIL Executive Board.

The members of the FIL will be informed of this decision in the next bulletin.

An official recognition (commissioning) and approval is in general only granted for **5 years**.

After expiration of this time period, the track operator has to apply for an extension.

Where construction measures have been performed in the meanwhile, the track has to be approved again. The commissioning can include requirements.

### 3.7 Buildings at the track

- ♦ Two start houses (men's start, women's start) with the following rooms:
  - 1 large room for use by the teams (for approximately 60 persons),
  - 1 room for press, radio, and television,
  - Toilets for men and women.
- ♦ Start houses at other start levels (juniors and youth),
  - 1 large room for use by the teams (for approx. 30 people),
  - Restrooms for women and men.
- ♦ A finish house with the following rooms:
  - 1 room for complete timing,
  - 1 room for jury and technical delegates,
  - 1 room for information services (press, radio, television),
  - 1 soundproof locked room for the announcer with a direct view of the finish and timing,
  - 1 first-aid room,
  - Restrooms for men and women,
  - 1 workshop (with necessary equipment),
  - 1 room for dignitaries,
- ♦ Inspection room directly at the finish outrun,
- ♦ Stands for honorary guests as well as facilities for press, radio and television above all within the start and finish areas,

Sketch I

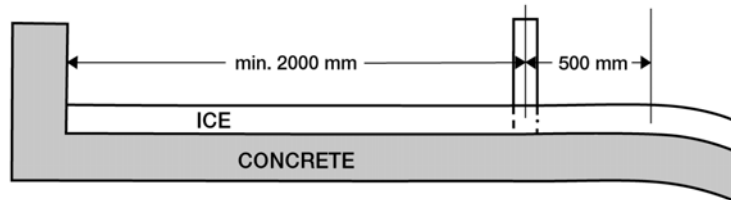

Sketch II

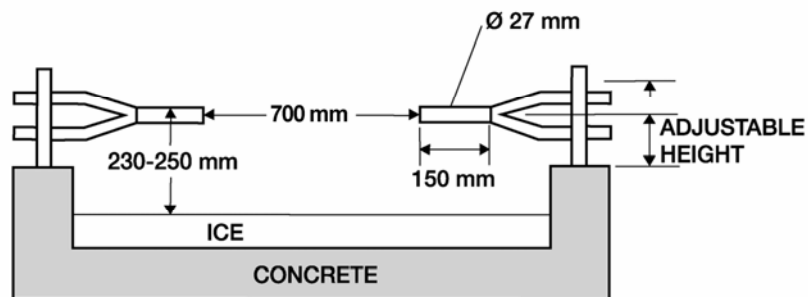

## **Supplement 2**

### **Rules for Instruction of International Judges**

#### **1. Basics**

- 1.1 The training regulation of the FIL is an obligatory work document for all National Federations associated with the FIL.
- 1.2 During all FIL competitions, judges from the respective NFs may only be appointed if they possess FIL International Judge Licenses acquired in accordance with these instruction regulations.
- 1.3 The NFs associated with the FIL have the right to conduct the instruction and qualification of international judges under their own responsibility.
- 1.4 Only persons who are full members of NFs associated with the FIL may be admitted to instruction and qualification as an international judge.
- 1.5 The International Judge License is personally issued to the applicant after an exam.
- 1.6 The FIL may withdraw an International Judge License for gross infractions against sportsmanship-like ethics and morals in the conduct of one's duties.

#### **2. Instruction**

- 2.1 The task of the NF is to select qualified persons who may be enrolled for instruction and qualification by the NFs for the International Judge License.  
The number of international judges instructed by a NF is not limited.
- 2.2 For instruction and qualification, the NF must appoint a head instructor and two assistants who have the necessary specialized knowledge to instruct the applicants.
- 2.3 The instruction and qualification must be under the supervision of the NF in accordance with the lesson plan of these instruction regulations and must not be under the prescribed 22 hours of instruction.
- 2.4 The period of instruction and qualification may not exceed six months measured from the beginning of instruction to the conclusion of the test.

#### **3. Lesson Plan**

- 3.1 All sections of the IRO.
- 3.2 All supplements of the IRO.
- 3.3 Practical work with measuring devices.
- 3.4 Working during a FIL competition with the assignment of special tasks and discussions.

#### **4. Composition of the Examination Commission**

- 4.1 FIL representative (proctor)
- 4.2 Chairperson of the Examination Commission
- 4.3 First assistant to the chairperson
- 4.4 Second assistant to the chairperson

**5. Responsibilities of the Examination Commission**

- 5.1 An Examination Commission is appointed by the NF to administer the final examination to the applicants.  
As a rule, the head instructor should belong to this commission.
- 5.2 The chairperson of the Examination Commission must inform the judge representative of the FIL of the examination date at least eight (8) weeks in advance of the examination so that the FIL proctor may be named and confirmed in writing to the NF.  
Expenses for the travel and accommodations of the FIL proctor are assumed by the NF.
- 5.3 A record is to be made concerning the results of the examination and its execution.  
This report must include the signatures of the Examination Commission and the FIL proctor with notation of the place and date of the examination.
- 5.4 The FIL proctor has to send this record to the judge representative of the FIL.

**6. Examination Regulations**

- 6.1 The examination is given in written and oral form.  
The examination documents are available from the judge representative of the FIL.
- 6.2 The Examination Commission determines the length of time for the examination.
- 6.3 Candidates who use external aids during the examination which seriously put their knowledge or ability into question will be disqualified.
- 6.4 The examination is passed when the applicant responds correctly to at least three quarters of the posed questions.
- 6.5 With the approval of the President of the FIL, a special examination may be conducted for a national coach who has been in this position for many years.

**7. Issuance of the International Judge License**

- 7.1 The representative of the FIL issues the International Judge License and the International Judge Badge to the applicants in question after they have successfully passed the examination.
- 7.2 The FIL distributes the International Judge License in the form of a passport identification booklet signed by the FIL President.
- 7.3 The names of FIL international judges are entered in the FIL Directory of International Officials according to their names and National Federation.
- 7.4 The FIL member NFs must grant international judges free entry to FIL competitions upon presentation of their identification card even if they are not working at the event(s).
- 7.5 The FIL Executive Board can withdraw the International Judge License from a judge, if he/she engages himself/herself in activities which harm the reputation of the FIL.

## Supplement 3

### **Regulations for Audio-Visual Media Rights**

#### **1. General**

- 1.1 The aim of the FIL is to promote the sport of luge worldwide. In order to come up to this challenge, it is necessary to establish uniform regulations for the coverage of the sport of luge via television, film and other new media (for example Internet) in order to achieve superb and worldwide media presence.
- 1.2 If there are no other regulations, the FIL is the exclusive and worldwide owner of the rights for audio-visual media for all events taking place on behalf of or with the approval of the FIL. The following rights belong to the subject audio-visual media:
- ◆ television (free or pay TV, all kinds of broadcasting, terrestrial, cable, satellite, etc.)
  - ◆ film (all formats)
  - ◆ video (all systems including video games, etc.)
  - ◆ projection rights
  - ◆ movie and video pictures on the internet
- 1.3 If these regulations are not considered, the respective competition can be cancelled from the international FIL events schedule for a certain period to be determined by the FIL Executive Board and/or it can result in sanctions against the respective NF.

#### **2. Award of Television Rights**

##### **2.1 International Competitions (with the exception of championships)**

- 2.1.1 The FIL authorizes the NFs affiliated with the FIL to make contracts on the awarding of the television rights which concern television broadcasts of luge events - except FIL Championships and Olympic Winter Games - which the Federation organizes in its country for the broadcasting area within its own country. The NF can delegate this responsibility to individual organizations belonging to the Federation. For the handing over of television rights to television companies outside the organizing country, the FIL is solely responsible.
- 2.1.2 Prior to signing them, all contract drafts are to be presented to the FIL for approval. The FIL can only withhold its approval due to an important reason. An important reason would be if the contract partner cannot furnish production and/or broadcasting guarantees (in sufficient technical quality) and/or the contract partner does not provide an international live signal. If six months prior to the event, no detailed contract offer has been presented, the FIL reserves the right to award a contract itself.
- 2.1.3 The NF or the event organizer authorized by the NF is obliged to grant the FIL free access to the live signal (signal with graphics and voice according to international standard).

##### **2.2 Championships**

Regarding an agreement with television stations concerning the broadcasting rights of FIL Championships, the FIL Executive Board acts together with the organizing NF. The FIL Executive Board makes the final resolution.

##### **2.3 Olympic Winter Games**

Agreements regarding the broadcasting rights of the Olympic Winter Games are the responsibility of the IOC.

- 2.4 **Commentator Booths**  
The NF or the event organizer authorized by the NF has to guarantee the FIL that sufficient commentator booths are available.
3. **Video, Film, and Other Rights**  
After agreement by the FIL, the NF is authorized by the FIL, to award the film and video rights in its own country, as long as it is guaranteed that marketing these rights abroad is not possible.
4. **Short Reports**  
The award of short report rights has to be done according to national and international regulations. If a respective request is made at the recording station, the FIL has to be informed at once.
5. **Financial Regulation**
- 5.1 **Television**  
For championships, the FIL is obliged to give 2/3 of the net income of the sales of the television rights (after deduction of possible taxes or other issue-related expenses) to the organizing NF.
- 5.2 **Video**  
The FIL has to give 2/3rds of the income of the selling of commercial film and video rights to the organizing NF.
6. **Miscellaneous**  
These regulations were acknowledged during the FIL Congress in Rome on June 24-25, 1994, and they were more precisely worded by the Congress in Colorado Springs in May 1998.



## Supplement 4

### **Olympic Rules**

#### **1. Validity**

For the luge competitions during Olympic Winter Games (OWG), the stipulations of the International Luge Regulations (IRO) are valid.

The following additional rules are valid for the OWG:

##### **1.1 Competition Runs**

- ♦ Singles: 4
- ♦ Doubles: 2
- ♦ Team Relay: 1

##### **1.2 Start Order**

Calculation of seeded groups for individual disciplines results from the World Cup point ranking of the three previous World Cup races from a minimum of three different tracks and a minimum of two different nations.

Singles (women and men)

1 <sup>st</sup> run	1 - 12 (A)	13 - 24 (B)	25 - 36 (C)	37 to last start no.
2 <sup>nd</sup> run	12 - 1 (A)	24 - 13 (B)	36 - 25 (C)	last start no. to 37

3<sup>rd</sup> run 1 - last place (according to placing after 2<sup>nd</sup> run)

4<sup>th</sup> run 20<sup>th</sup> place to 1<sup>st</sup> place (according to placing after 3<sup>rd</sup> run)

- ♦ Athletes, which do not qualify for the 4<sup>th</sup> competition run, will be ranked according to their placing in the 3<sup>rd</sup> competition run.

Doubles

1<sup>st</sup> run 1 - 12 (A) 13 - 24 (B) 25 - end

2<sup>nd</sup> run last place to first place (according to placing after 1<sup>st</sup> run)

Track preparation before the best 10 doubles teams, if required by the Technical Delegates.

Team Relay (IRO § 3, 6.4)

- Determination of the nation ranking for the Team Relay competition according to the IRO
- § 3, 6.4.4.1
- Start order, according to the nation ranking for the Team Relay at OWS in reverse order (§ 3, 6.4.6)

##### **1.3 Maximum Numbers of Participants per National Federation**

- ♦ Women 3
- ♦ Men 3
- ♦ Doubles 2

##### **1.4 Education of International Judges**

The Organizing Committee (OC) of the Olympic Winter Games is responsible for the education of the judges appointed for the Olympic Winter Games and has to take care of the respective expenses.

##### **1.5 Advertising Regulations**

The regulations of the IOC are valid.

##### **1.6 Nominations / Entry Fee**

According to the regulations of the IOC, the nominations have to be made by the NOC responsible to the OC on the stipulated dates.

The Executive Board of the FIL is to be constantly informed on the nominations by the OC.

No entry fee has to be paid.

1.7 **Inspections at the Finish**

The inspection weigh-in of the additional weight, the race clothing and the sled, the inspection of the runners as well as the measuring of the sled and the seat (pod) take place at the finish as follows:

Singles:	1st and 3rd run, 2nd and 4th run,	6 drawn athletes, 3 of them from group A no draw
Doubles:	1st run, 2nd run,	3 drawn doubles no draw

1.8 **Withdrawal Due to Injury / Sickness**

If, during training, an athlete who is nominated for the participation in the singles discipline withdraws due to injury / sickness, then another athlete who belongs to the Olympic team and has completed the minimum number of training runs can be nominated instead.

1.9 **Training**

The Olympic training will be regulated as follows:

- ◆ 1 systematic training run per discipline
- ◆ 6 training runs per discipline over 3 days

Training groups of NFs may be established by the FIL and Organizing Committee to standardize group size.

- ◆ 1st training day, training by groups according to draw of NFs
- ◆ 2<sup>nd</sup> training day, training by groups in reversed order of NFs

Note: On 1<sup>st</sup> and 2<sup>nd</sup> Training days, nations with partnership programs may be placed into the same training group, but the draw within their group will be done by individual nations.

- ◆ 3<sup>rd</sup> training day: joint training according to new draw (no groupings, all nations drawn individually).
- ◆ Each day, in accordance with the draw
  - 1<sup>st</sup> training run first to last by NF,
  - track maintenance,
  - 2<sup>nd</sup> training run last to first by NF.
- ◆ Doubles drivers who participate in singles training can not participate in singles training assigned to doubles drivers, and they get no systematic run in doubles.  
In case only one athlete from a doubles team participates in singles training, the doubles team can take the systematic run in doubles.
- ◆ If a time difference of two (2) or more days exists between two (2) race runs of a discipline, then at least one (1) training run must be added for the athletes participating in the competition before the next race run.
- ◆ If a time difference of two (2) or more days exists between two (2) training runs of a discipline, then at least one (1) additional training run must be offered for the athletes participating in the competition.
- ◆ If a time difference of two (2) or more days exists between the last training and the first race runs of any discipline, then at least one (1) additional training run must be offered for the athletes participating in the competition. For the Team Relay competition, this is calculated per discipline.

1.10 **International Training Courses on the Olympic Track**

The organizers of the Olympic luge competitions are obligated to offer in the pre-Olympic and the Olympic season altogether two International Training Weeks for all NFs.

At least 6 training days with at least 3 training runs per day are to be made available in each week. The same number of training runs must be made available to all NF's; cancelled training

runs must be replaced. During these two International Training Weeks, no privileges are granted to athletes of the host nation.

The Executive Board of the FIL will decide on possible training restrictions during the Olympic season

1.11 **Test Race**

One year prior to the OWG, the track has to be available to the FIL for a test competition open to all NFs, during the same time period as the Games are scheduled.

The technical delegates of the FIL present at the test race have to examine the track regarding its safety and the technical facilities.

The OC and the staging NF have to be informed on the result of the test race in writing. Complaints have to be fully remedied prior to the staging of the OWG.

2. **Preparation and Staging**

2.1 **The FIL as Highest Body**

The FIL is responsible to the IOC for the proper staging of luge competitions.

The FIL is the highest body of these competitions. In order to meet this task, the FIL appoints and sends the following persons at the expense of the OC during the staging of the Olympic luge program:

- ◆ the President and the General Secretary (they officially represent the FIL),
- ◆ the jury, consisting of the chairperson and two members,
- ◆ the technical delegates, consisting of three persons,
- ◆ additional international judges  
(the number is coordinated between the IOC, the OC and the FIL)
- ◆ two IOC technical delegates who have to provide the permanent contact to the IOC.

For the jury, technical delegates, and IOC technical delegates, walkie-talkies with independent frequencies have to be provided.

2.2 **Responsibility of the National Federation**

The National Federation in cooperation with the OC of the OWG is responsible for the organization of the Olympic luge competitions.

A permanent and close cooperation between the National Federation, OC and the FIL starting with the preparation work until the completion of the Olympic luge competitions is necessary.

A sport office / luge department has to be provided by the OC for the luge competitions and a full-time director has to be appointed.

The National Federation responsible must be represented in a leadership position by its president or by an elected chairperson.

2.3 **Officials, Judges, Assistants**

Each NF hosting Olympic luge competitions should have approximately 30 international judges who should already be working during the pre-Olympic test.

The FIL supports the required education and training. Judges who have important tasks during the OWG (race leader, start and finish leaders, chief of track and their representatives) should gain experience already prior to the OWG during important FIL competitions.

The following officials / judges / assistants are required for the Olympic luge competitions:

- ◆ organizing chairperson
- ◆ assistant chairperson
- ◆ 3 - 6 officials in the luge sport office / luge department
- ◆ press chief
- ◆ race director
- ◆ assistant race director
- ◆ start leader
- ◆ assistant start leader
- ◆ 2 assistants at the start
- ◆ starter
- ◆ finish leader

- ◆ assistant finish leader
  - ◆ 2 assistants at the finish
  - ◆ person in charge of weigh in
  - ◆ recorder for weigh-in
  - ◆ assistant for weigh-in
  - ◆ ice experts
  - ◆ chief of track
  - ◆ assistant track chief
  - ◆ chief of timing
  - ◆ assistant chief of timing
  - ◆ 2 persons to check the temperature of the runners
  - ◆ 2 persons to keep the records of this inspection
  - ◆ chief of transport
  - ◆ announcer for the track loudspeaker system
  - ◆ assistant for the announcer
  - ◆ 2 - 3 translators
  - ◆ track workers for track building and maintenance
- Total required: approximately 45 - 60 persons.  
 If the weather conditions are unfavorable, approximately 50 additional persons are required to work at the track (snow removal, etc.). Some of these positions may be employed and others are as a volunteer.

2.4 **Program / Time Schedule**

By paying attention to the overall planning of the Olympic Winter Games, the organizers (OC and NF) propose the detailed Olympic luge schedule to the FIL in time.  
 The schedule has to be approved by the FIL Executive Board.  
 Changes which are determined by the FIL Executive Board are binding and have to be met by the organizers (OC).

2.5 **Interpreters**

A sufficient number of interpreters fluent in German and English have to be available for the officials.

3. **Luge Tracks**

In general, Olympic luge competitions are staged on combined bobsleigh, luge and skeleton tracks with artificial refrigeration.  
 The "Regulation for Artificial Luge Tracks" (Supplement 1) is valid.

4. **Eligibility Rules**

With regard to permission to participate in the Olympic Winter Games, the qualification criteria as agreed on and amended by the FIL and the IOC will apply.  
 In individual and justified cases, the FIL Executive Board can make exceptions.

5. **Doping Controls**

The regulations of the IOC are valid.

## Supplement 5

### Individual Weight Allowances

**Men:**

Additional Weight Allowance (AW) = 100% of the difference between 90 kg and  
body weight (BW) (max. 13 kg)

Total Weight Allowance (TW) = BW + AW + 4 kg Race Clothing (RC)

<b>Body Weight</b>	<b>Additional Weight</b>	<b>Race Clothing</b>	<b>Total Weight</b>	<b>Total</b>
<b>BW in kg</b>	<b>AW in kg</b>	<b>RC in kg</b>	<b>TW in kg</b>	<b>with Sled</b>
72,7	13,0	4,0	89,7	112,7
72,8	13,0	4,0	89,8	112,8
72,9	13,0	4,0	89,9	112,9
<b>73,0</b>	<b>13,0</b>	<b>4,0</b>	<b>90,0</b>	<b>113,0</b>
73,1	13,0	4,0	90,1	113,1
73,2	13,0	4,0	90,2	113,2
73,3	13,0	4,0	90,3	113,3
73,4	13,0	4,0	90,4	113,4
73,5	13,0	4,0	90,5	113,5
73,6	13,0	4,0	90,6	113,6
73,7	13,0	4,0	90,7	113,7
73,8	13,0	4,0	90,8	113,8
73,9	13,0	4,0	90,9	113,9
<b>74,0</b>	<b>13,0</b>	<b>4,0</b>	<b>91,0</b>	<b>114,0</b>
74,1	13,0	4,0	91,1	114,1
74,2	13,0	4,0	91,2	114,2
74,3	13,0	4,0	91,3	114,3
74,4	13,0	4,0	91,4	114,4
74,5	13,0	4,0	91,5	114,5
74,6	13,0	4,0	91,6	114,6
74,7	13,0	4,0	91,7	114,7
74,8	13,0	4,0	91,8	114,8
74,9	13,0	4,0	91,9	114,9
<b>75,0</b>	<b>13,0</b>	<b>4,0</b>	<b>92,0</b>	<b>115,0</b>

<b>Body Weight</b> <b>BW in kg</b>	<b>Add. Weight</b> <b>AW in kg</b>	<b>Race Clothing</b> <b>RC in kg</b>	<b>Total Weight</b> <b>TW in kg</b>	<b>Total</b> <b>with Sled</b>
75,1	13,0	4,0	92,1	115,1
75,2	13,0	4,0	92,2	115,2
75,3	13,0	4,0	92,3	115,3
75,4	13,0	4,0	92,4	115,4
75,5	13,0	4,0	92,5	115,5
75,6	13,0	4,0	92,6	115,6
75,7	13,0	4,0	92,7	115,7
75,8	13,0	4,0	92,8	115,8
75,9	13,0	4,0	92,9	115,9
<b>76,0</b>	<b>13,0</b>	<b>4,0</b>	<b>93,0</b>	<b>116,0</b>
76,1	13,0	4,0	93,1	116,1
76,2	13,0	4,0	93,2	116,2
76,3	13,0	4,0	93,3	116,3
76,4	13,0	4,0	93,4	116,4
76,5	13,0	4,0	93,5	116,5
76,6	13,0	4,0	93,6	116,6
76,7	13,0	4,0	93,7	116,7
76,8	13,0	4,0	93,8	116,8
76,9	13,0	4,0	93,9	116,9
<b>77,0</b>	<b>13,0</b>	<b>4,0</b>	<b>94,0</b>	<b>117,0</b>
77,1	12,9	4,0	94,0	117,0
77,2	12,8	4,0	94,0	117,0
77,3	12,7	4,0	94,0	117,0
77,4	12,6	4,0	94,0	117,0
77,5	12,5	4,0	94,0	117,0
77,6	12,4	4,0	94,0	117,0
77,7	12,3	4,0	94,0	117,0
77,8	12,2	4,0	94,0	117,0
77,9	12,1	4,0	94,0	117,0
<b>78,0</b>	<b>12,0</b>	<b>4,0</b>	<b>94,0</b>	<b>117,0</b>
78,1	11,9	4,0	94,0	117,0
78,2	11,8	4,0	94,0	117,0
78,3	11,7	4,0	94,0	117,0

<b>Body Weight</b> <b>BW in kg</b>	<b>Add. Weight</b> <b>AW in kg</b>	<b>Race Clothing</b> <b>RC in kg</b>	<b>Total Weight</b> <b>TW in kg</b>	<b>Total</b> <b>with Sled</b>
78,4	11,6	4,0	94,0	117,0
78,5	11,5	4,0	94,0	117,0
78,6	11,4	4,0	94,0	117,0
78,7	11,3	4,0	94,0	117,0
78,8	11,2	4,0	94,0	117,0
78,9	11,1	4,0	94,0	117,0
<b>79,0</b>	<b>11,0</b>	<b>4,0</b>	<b>94,0</b>	<b>117,0</b>
79,1	10,9	4,0	94,0	117,0
79,2	10,8	4,0	94,0	117,0
79,3	10,7	4,0	94,0	117,0
79,4	10,6	4,0	94,0	117,0
79,5	10,5	4,0	94,0	117,0
79,6	10,4	4,0	94,0	117,0
79,7	10,3	4,0	94,0	117,0
79,8	10,2	4,0	94,0	117,0
79,9	10,1	4,0	94,0	117,0
<b>80,0</b>	<b>10,0</b>	<b>4,0</b>	<b>94,0</b>	<b>117,0</b>
80,1	9,9	4,0	94,0	117,0
80,2	9,8	4,0	94,0	117,0
80,3	9,7	4,0	94,0	117,0
80,4	9,6	4,0	94,0	117,0
80,5	9,5	4,0	94,0	117,0
80,6	9,4	4,0	94,0	117,0
80,7	9,3	4,0	94,0	117,0
80,8	9,2	4,0	94,0	117,0
80,9	9,1	4,0	94,0	117,0
<b>81,0</b>	<b>9,0</b>	<b>4,0</b>	<b>94,0</b>	<b>117,0</b>
81,1	8,9	4,0	94,0	117,0
81,2	8,8	4,0	94,0	117,0
81,3	8,7	4,0	94,0	117,0
81,4	8,6	4,0	94,0	117,0
81,5	8,5	4,0	94,0	117,0

<b>Body Weight</b> <b>BW in kg</b>	<b>Add. Weight</b> <b>AW in kg</b>	<b>Race Clothing</b> <b>RC in kg</b>	<b>Total Weight</b> <b>TW in kg</b>	<b>Total</b> <b>with Sled</b>
81,6	8,4	4,0	94,0	117,0
81,7	8,3	4,0	94,0	117,0
81,8	8,2	4,0	94,0	117,0
81,9	8,1	4,0	94,0	117,0
<b>82,0</b>	<b>8,0</b>	<b>4,0</b>	<b>94,0</b>	<b>117,0</b>
82,1	7,9	4,0	94,0	117,0
82,2	7,8	4,0	94,0	117,0
82,3	7,7	4,0	94,0	117,0
82,4	7,6	4,0	94,0	117,0
82,5	7,5	4,0	94,0	117,0
82,6	7,4	4,0	94,0	117,0
82,7	7,3	4,0	94,0	117,0
82,8	7,2	4,0	94,0	117,0
82,9	7,1	4,0	94,0	117,0
<b>83,0</b>	<b>7,0</b>	<b>4,0</b>	<b>94,0</b>	<b>117,0</b>
83,1	6,9	4,0	94,0	117,0
83,2	6,8	4,0	94,0	117,0
83,3	6,7	4,0	94,0	117,0
83,4	6,6	4,0	94,0	117,0
83,5	6,5	4,0	94,0	117,0
83,6	6,4	4,0	94,0	117,0
83,7	6,3	4,0	94,0	117,0
83,8	6,2	4,0	94,0	117,0
83,9	6,1	4,0	94,0	117,0
<b>84,0</b>	<b>6,0</b>	<b>4,0</b>	<b>94,0</b>	<b>117,0</b>
84,1	5,9	4,0	94,0	117,0
84,2	5,8	4,0	94,0	117,0
84,3	5,7	4,0	94,0	117,0
84,4	5,6	4,0	94,0	117,0
84,5	5,5	4,0	94,0	117,0
84,6	5,4	4,0	94,0	117,0
84,7	5,3	4,0	94,0	117,0



<b>Body Weight</b> <b>BW in kg</b>	<b>Add. Weight</b> <b>AW in kg</b>	<b>Race Clothing</b> <b>RC in kg</b>	<b>Total Weight</b> <b>TW in kg</b>	<b>Total</b> <b>with Sled</b>
84,8	5,2	4,0	94,0	117,0
84,9	5,1	4,0	94,0	117,0
<b>85,0</b>	<b>5,0</b>	<b>4,0</b>	<b>94,0</b>	<b>117,0</b>
85,1	4,9	4,0	94,0	117,0
85,2	4,8	4,0	94,0	117,0
85,3	4,7	4,0	94,0	117,0
85,4	4,6	4,0	94,0	117,0
85,5	4,5	4,0	94,0	117,0
85,6	4,4	4,0	94,0	117,0
85,7	4,3	4,0	94,0	117,0
85,8	4,2	4,0	94,0	117,0
85,9	4,1	4,0	94,0	117,0
<b>86,0</b>	<b>4,0</b>	<b>4,0</b>	<b>94,0</b>	<b>117,0</b>
86,1	3,9	4,0	94,0	117,0
86,2	3,8	4,0	94,0	117,0
86,3	3,7	4,0	94,0	117,0
86,4	3,6	4,0	94,0	117,0
86,5	3,5	4,0	94,0	117,0
86,6	3,4	4,0	94,0	117,0
86,7	3,3	4,0	94,0	117,0
86,8	3,2	4,0	94,0	117,0
86,9	3,1	4,0	94,0	117,0
<b>87,0</b>	<b>3,0</b>	<b>4,0</b>	<b>94,0</b>	<b>117,0</b>
87,1	2,9	4,0	94,0	117,0
87,2	2,8	4,0	94,0	117,0
87,3	2,7	4,0	94,0	117,0
87,4	2,6	4,0	94,0	117,0
87,5	2,5	4,0	94,0	117,0
87,6	2,4	4,0	94,0	117,0
87,7	2,3	4,0	94,0	117,0
87,8	2,2	4,0	94,0	117,0
87,9	2,1	4,0	94,0	117,0
<b>88,0</b>	<b>2,0</b>	<b>4,0</b>	<b>94,0</b>	<b>117,0</b>

<b>Body Weight</b> <b>BW in kg</b>	<b>Add. Weight</b> <b>AW in kg</b>	<b>Race Clothing</b> <b>RC in kg</b>	<b>Total Weight</b> <b>TW in kg</b>	<b>Total</b> <b>with Sled</b>
88,1	1,9	4,0	94,0	117,0
88,2	1,8	4,0	94,0	117,0
88,3	1,7	4,0	94,0	117,0
88,4	1,6	4,0	94,0	117,0
88,5	1,5	4,0	94,0	117,0
88,6	1,4	4,0	94,0	117,0
88,7	1,3	4,0	94,0	117,0
88,8	1,2	4,0	94,0	117,0
88,9	1,1	4,0	94,0	117,0
<b>89,0</b>	<b>1,0</b>	<b>4,0</b>	<b>94,0</b>	<b>117,0</b>
89,1	0,9	4,0	94,0	117,0
89,2	0,8	4,0	94,0	117,0
89,3	0,7	4,0	94,0	117,0
89,4	0,6	4,0	94,0	117,0
89,5	0,5	4,0	94,0	117,0
89,6	0,4	4,0	94,0	117,0
89,7	0,3	4,0	94,0	117,0
89,8	0,2	4,0	94,0	117,0
89,9	0,1	4,0	94,0	117,0
<b>90,0</b>	<b>0,0</b>	<b>4,0</b>	<b>94,0</b>	<b>117,0</b>

**Women:**

AW = 100% of the difference between 75 kg and body weight (BW) (max. 10 kg)

TW = BW + AW + 4 kg RC

<b>Body Weight BW in kg</b>	<b>Additional Weight AW in kg</b>	<b>Race Clothing RC in kg</b>	<b>Total Weight TW in kg</b>	<b>Total with Sled</b>
61,7	10,0	4,0	75,7	98,7
61,8	10,0	4,0	75,8	98,8
61,9	10,0	4,0	75,9	98,9
<b>62,0</b>	<b>10,0</b>	<b>4,0</b>	<b>76,0</b>	<b>99,0</b>
62,1	10,0	4,0	76,1	99,1
62,2	10,0	4,0	76,2	99,2
62,3	10,0	4,0	76,3	99,3
62,4	10,0	4,0	76,4	99,4
62,5	10,0	4,0	76,5	99,5
62,6	10,0	4,0	76,6	99,6
62,7	10,0	4,0	76,7	99,7
62,8	10,0	4,0	76,8	99,8
62,9	10,0	4,0	76,9	99,9
<b>63,0</b>	<b>10,0</b>	<b>4,0</b>	<b>77,0</b>	<b>100,0</b>
63,1	10,0	4,0	77,1	100,1
63,2	10,0	4,0	77,2	100,2
63,3	10,0	4,0	77,3	100,3
63,4	10,0	4,0	77,4	100,4
63,5	10,0	4,0	77,5	100,5
63,6	10,0	4,0	77,6	100,6
63,7	10,0	4,0	77,7	100,7
63,8	10,0	4,0	77,8	100,8
63,9	10,0	4,0	77,9	100,9
<b>64,0</b>	<b>10,0</b>	<b>4,0</b>	<b>78,0</b>	<b>101,0</b>
64,1	10,0	4,0	78,1	101,1
64,2	10,0	4,0	78,2	101,2
64,3	10,0	4,0	78,3	101,3
64,4	10,0	4,0	78,4	101,4

<b>Body Weight</b> <b>BW in kg</b>	<b>Add. Weight</b> <b>AW in kg</b>	<b>Race Clothing</b> <b>RC in kg</b>	<b>Total Weight</b> <b>TW in kg</b>	<b>Total</b> <b>with Sled</b>
64,5	10,0	4,0	78,5	101,5
64,6	10,0	4,0	78,6	101,6
64,7	10,0	4,0	78,7	101,7
64,8	10,0	4,0	78,8	101,8
64,9	10,0	4,0	78,9	101,9
<b>65,0</b>	<b>10,0</b>	<b>4,0</b>	<b>79,0</b>	<b>102,0</b>
65,1	9,9	4,0	79,0	102,0
65,2	9,8	4,0	79,0	102,0
65,3	9,7	4,0	79,0	102,0
65,4	9,6	4,0	79,0	102,0
65,5	9,5	4,0	79,0	102,0
65,6	9,4	4,0	79,0	102,0
65,7	9,3	4,0	79,0	102,0
65,8	9,2	4,0	79,0	102,0
65,9	9,1	4,0	79,0	102,0
<b>66,0</b>	<b>9,0</b>	<b>4,0</b>	<b>79,0</b>	<b>102,0</b>
66,1	8,9	4,0	79,0	102,0
66,2	8,8	4,0	79,0	102,0
66,3	8,7	4,0	79,0	102,0
66,4	8,6	4,0	79,0	102,0
66,5	8,5	4,0	79,0	102,0
66,6	8,4	4,0	79,0	102,0
66,7	8,3	4,0	79,0	102,0
66,8	8,2	4,0	79,0	102,0
66,9	8,1	4,0	79,0	102,0
<b>67,0</b>	<b>8,0</b>	<b>4,0</b>	<b>79,0</b>	<b>102,0</b>
67,1	7,9	4,0	79,0	102,0
67,2	7,8	4,0	79,0	102,0
67,3	7,7	4,0	79,0	102,0
67,4	7,6	4,0	79,0	102,0
67,5	7,5	4,0	79,0	102,0
67,6	7,4	4,0	79,0	102,0

<b>Body Weight</b> <b>BW in kg</b>	<b>Add. Weight</b> <b>AW in kg</b>	<b>Race Clothing</b> <b>RC in kg</b>	<b>Total Weight</b> <b>TW in kg</b>	<b>Total</b> <b>with Sled</b>
67,7	7,3	4,0	79,0	102,0
67,8	7,2	4,0	79,0	102,0
67,9	7,1	4,0	79,0	102,0
<b>68,0</b>	<b>7,0</b>	<b>4,0</b>	<b>79,0</b>	<b>102,0</b>
68,1	6,9	4,0	79,0	102,0
68,2	6,8	4,0	79,0	102,0
68,3	6,7	4,0	79,0	102,0
68,4	6,6	4,0	79,0	102,0
68,5	6,5	4,0	79,0	102,0
68,6	6,4	4,0	79,0	102,0
68,7	6,3	4,0	79,0	102,0
68,8	6,2	4,0	79,0	102,0
68,9	6,1	4,0	79,0	102,0
<b>69,0</b>	<b>6,0</b>	<b>4,0</b>	<b>79,0</b>	<b>102,0</b>
69,1	5,9	4,0	79,0	102,0
69,2	5,8	4,0	79,0	102,0
69,3	5,7	4,0	79,0	102,0
69,4	5,6	4,0	79,0	102,0
69,5	5,5	4,0	79,0	102,0
69,6	5,4	4,0	79,0	102,0
69,7	5,3	4,0	79,0	102,0
69,8	5,2	4,0	79,0	102,0
69,9	5,1	4,0	79,0	102,0
<b>70,0</b>	<b>5,0</b>	<b>4,0</b>	<b>79,0</b>	<b>102,0</b>
70,1	4,9	4,0	79,0	102,0
70,2	4,8	4,0	79,0	102,0
70,3	4,7	4,0	79,0	102,0
70,4	4,6	4,0	79,0	102,0
70,5	4,5	4,0	79,0	102,0
70,6	4,4	4,0	79,0	102,0
70,7	4,3	4,0	79,0	102,0
70,8	4,2	4,0	79,0	102,0

<b>Body Weight</b> <b>BW in kg</b>	<b>Add. Weight</b> <b>AW in kg</b>	<b>Race Clothing</b> <b>RC in kg</b>	<b>Total Weight</b> <b>TW in kg</b>	<b>Total</b> <b>with Sled</b>
70,9	4,1	4,0	79,0	102,0
<b>71,0</b>	<b>4,0</b>	<b>4,0</b>	<b>79,0</b>	<b>102,0</b>
71,1	3,9	4,0	79,0	102,0
71,2	3,8	4,0	79,0	102,0
71,3	3,7	4,0	79,0	102,0
71,4	3,6	4,0	79,0	102,0
71,5	3,5	4,0	79,0	102,0
71,6	3,4	4,0	79,0	102,0
71,7	3,3	4,0	79,0	102,0
71,8	3,2	4,0	79,0	102,0
71,9	3,1	4,0	79,0	102,0
<b>72,0</b>	<b>3,0</b>	<b>4,0</b>	<b>79,0</b>	<b>102,0</b>
72,1	2,9	4,0	79,0	102,0
72,2	2,8	4,0	79,0	102,0
72,3	2,7	4,0	79,0	102,0
72,4	2,6	4,0	79,0	102,0
72,5	2,5	4,0	79,0	102,0
72,6	2,4	4,0	79,0	102,0
72,7	2,3	4,0	79,0	102,0
72,8	2,2	4,0	79,0	102,0
72,9	2,1	4,0	79,0	102,0
<b>73,0</b>	<b>2,0</b>	<b>4,0</b>	<b>79,0</b>	<b>102,0</b>
73,1	1,9	4,0	79,0	102,0
73,2	1,8	4,0	79,0	102,0
73,3	1,7	4,0	79,0	102,0
73,4	1,6	4,0	79,0	102,0
73,5	1,5	4,0	79,0	102,0
73,6	1,4	4,0	79,0	102,0
73,7	1,3	4,0	79,0	102,0
73,8	1,2	4,0	79,0	102,0
73,9	1,1	4,0	79,0	102,0
<b>74,0</b>	<b>1,0</b>	<b>4,0</b>	<b>79,0</b>	<b>102,0</b>

<b>Body Weight</b> <b>BW in kg</b>	<b>Add. Weight</b> <b>AW in kg</b>	<b>Race Clothing</b> <b>RC in kg</b>	<b>Total Weight</b> <b>TW in kg</b>	<b>Total</b> <b>with Sled</b>
74,1	0,9	4,0	79,0	102,0
74,2	0,8	4,0	79,0	102,0
74,3	0,7	4,0	79,0	102,0
74,4	0,6	4,0	79,0	102,0
74,5	0,5	4,0	79,0	102,0
74,6	0,4	4,0	79,0	102,0
74,7	0,3	4,0	79,0	102,0
74,8	0,2	4,0	79,0	102,0
74,9	0,1	4,0	79,0	102,0
<b>75,0</b>	<b>0,0</b>	<b>4,0</b>	<b>79,0</b>	<b>102,0</b>

**Men's doubles:**

AW = 75% of the difference between 90 kg and BW (max. 10 kg)

TW = BW + AW + 4 kg RC

<b>Body Weight</b> <b>BW in kg</b>	<b>Additional Weight</b> <b>AW in kg</b>	<b>Race Clothing</b> <b>RC in kg</b>	<b>Total Weight</b> <b>TW in kg</b>	<b>Total</b> <b>with Sled</b>
<b>70,0</b>	<b>10,0</b>	<b>4,0</b>	<b>84,0</b>	<b>111,0</b>
70,1	10,0	4,0	84,1	111,1
70,2	10,0	4,0	84,2	111,2
70,3	10,0	4,0	84,3	111,3
70,4	10,0	4,0	84,4	111,4
70,5	10,0	4,0	84,5	111,5
70,6	10,0	4,0	84,6	111,6
70,7	10,0	4,0	84,7	111,7
70,8	10,0	4,0	84,8	111,8
70,9	10,0	4,0	84,9	111,9
<b>71,0</b>	<b>10,0</b>	<b>4,0</b>	<b>85,0</b>	<b>112,0</b>
71,1	10,0	4,0	85,1	112,1
71,2	10,0	4,0	85,2	112,2
71,3	10,0	4,0	85,3	112,3
71,4	10,0	4,0	85,4	112,4
71,5	10,0	4,0	85,5	112,5
71,6	10,0	4,0	85,6	112,6
71,7	10,0	4,0	85,7	112,7
71,8	10,0	4,0	85,8	112,8
71,9	10,0	4,0	85,9	112,9
<b>72,0</b>	<b>10,0</b>	<b>4,0</b>	<b>86,0</b>	<b>113,0</b>
72,1	10,0	4,0	86,1	113,1
72,2	10,0	4,0	86,2	113,2
72,3	10,0	4,0	86,3	113,3
72,4	10,0	4,0	86,4	113,4
72,5	10,0	4,0	86,5	113,5
72,6	10,0	4,0	86,6	113,6
72,7	10,0	4,0	86,7	113,7



<b>Body Weight</b> <b>BW in kg</b>	<b>Add. Weight</b> <b>AW in kg</b>	<b>Race Clothing</b> <b>RC in kg</b>	<b>Total Weight</b> <b>TW in kg</b>	<b>Total</b> <b>with Sled</b>
72,8	10,0	4,0	86,8	113,8
72,9	10,0	4,0	86,9	113,9
<b>73,0</b>	<b>10,0</b>	<b>4,0</b>	<b>87,0</b>	<b>114,0</b>
73,1	10,0	4,0	87,1	114,1
73,2	10,0	4,0	87,2	114,2
73,3	10,0	4,0	87,3	114,3
73,4	10,0	4,0	87,4	114,4
73,5	10,0	4,0	87,5	114,5
73,6	10,0	4,0	87,6	114,6
73,7	10,0	4,0	87,7	114,7
73,8	10,0	4,0	87,8	114,8
73,9	10,0	4,0	87,9	114,9
<b>74,0</b>	<b>10,0</b>	<b>4,0</b>	<b>88,0</b>	<b>115,0</b>
74,1	10,0	4,0	88,1	115,1
74,2	10,0	4,0	88,2	115,2
74,3	10,0	4,0	88,3	115,3
74,4	10,0	4,0	88,4	115,4
74,5	10,0	4,0	88,5	115,5
74,6	10,0	4,0	88,6	115,6
74,7	10,0	4,0	88,7	115,7
74,8	10,0	4,0	88,8	115,8
74,9	10,0	4,0	88,9	115,9
<b>75,0</b>	<b>10,0</b>	<b>4,0</b>	<b>89,0</b>	<b>116,0</b>
75,1	10,0	4,0	89,1	116,1
75,2	10,0	4,0	89,2	116,2
75,3	10,0	4,0	89,3	116,3
75,4	10,0	4,0	89,4	116,4
75,5	10,0	4,0	89,5	116,5
75,6	10,0	4,0	89,6	116,6
75,7	10,0	4,0	89,7	116,7
75,8	10,0	4,0	89,8	116,8
75,9	10,0	4,0	89,9	116,9

<b>Body Weight</b> <b>BW in kg</b>	<b>Add. Weight</b> <b>AW in kg</b>	<b>Race Clothing</b> <b>RC in kg</b>	<b>Total Weight</b> <b>TW in kg</b>	<b>Total</b> <b>with Sled</b>
<b>76,0</b>	<b>10,0</b>	<b>4,0</b>	<b>90,0</b>	<b>117,0</b>
76,1	10,0	4,0	90,1	117,1
76,2	10,0	4,0	90,2	117,2
76,3	10,0	4,0	90,3	117,3
76,4	10,0	4,0	90,4	117,4
76,5	10,0	4,0	90,5	117,5
76,6	10,0	4,0	90,6	117,6
76,7	10,0	4,0	90,7	117,7
76,8	9,9	4,0	90,7	117,7
76,9	9,8	4,0	90,7	117,7
<b>77,0</b>	<b>9,8</b>	<b>4,0</b>	<b>90,8</b>	<b>117,8</b>
77,1	9,7	4,0	90,8	117,8
77,2	9,6	4,0	90,8	117,8
77,3	9,5	4,0	90,8	117,8
77,4	9,5	4,0	90,9	117,9
77,5	9,4	4,0	90,9	117,9
77,6	9,3	4,0	90,9	117,9
77,7	9,2	4,0	90,9	117,9
77,8	9,2	4,0	91,0	118,0
77,9	9,1	4,0	91,0	118,0
<b>78,0</b>	<b>9,0</b>	<b>4,0</b>	<b>91,0</b>	<b>118,0</b>
78,1	8,9	4,0	91,0	118,0
78,2	8,9	4,0	91,1	118,1
78,3	8,8	4,0	91,1	118,1
78,4	8,7	4,0	91,1	118,1
78,5	8,6	4,0	91,1	118,1
78,6	8,6	4,0	91,2	118,2
78,7	8,5	4,0	91,2	118,2
78,8	8,4	4,0	91,2	118,2
78,9	8,3	4,0	91,2	118,2
<b>79,0</b>	<b>8,3</b>	<b>4,0</b>	<b>91,3</b>	<b>118,3</b>
79,1	8,2	4,0	91,3	118,3

<b>Body Weight</b> <b>BW in kg</b>	<b>Add. Weight</b> <b>AW in kg</b>	<b>Race Clothing</b> <b>RC in kg</b>	<b>Total Weight</b> <b>TW in kg</b>	<b>Total</b> <b>with Sled</b>
79,2	8,1	4,0	91,3	118,3
79,3	8,0	4,0	91,3	118,3
79,4	8,0	4,0	91,4	118,4
79,5	7,9	4,0	91,4	118,4
79,6	7,8	4,0	91,4	118,4
79,7	7,7	4,0	91,4	118,4
79,8	7,7	4,0	91,5	118,5
79,9	7,6	4,0	91,5	118,5
<b>80,0</b>	<b>7,5</b>	<b>4,0</b>	<b>91,5</b>	<b>118,5</b>
80,1	7,4	4,0	91,5	118,5
80,2	7,4	4,0	91,6	118,6
80,3	7,3	4,0	91,6	118,6
80,4	7,2	4,0	91,6	118,6
80,5	7,1	4,0	91,6	118,6
80,6	7,1	4,0	91,7	118,7
80,7	7,0	4,0	91,7	118,7
80,8	6,9	4,0	91,7	118,7
80,9	6,8	4,0	91,7	118,7
<b>81,0</b>	<b>6,8</b>	<b>4,0</b>	<b>91,8</b>	<b>118,8</b>
81,1	6,7	4,0	91,8	118,8
81,2	6,6	4,0	91,8	118,8
81,3	6,5	4,0	91,8	118,8
81,4	6,5	4,0	91,9	118,9
81,5	6,4	4,0	91,9	118,9
81,6	6,3	4,0	91,9	118,9
81,7	6,2	4,0	91,9	118,9
81,8	6,2	4,0	92,0	119,0
81,9	6,1	4,0	92,0	119,0
<b>82,0</b>	<b>6,0</b>	<b>4,0</b>	<b>92,0</b>	<b>119,0</b>
82,1	5,9	4,0	92,0	119,0
82,2	5,9	4,0	92,1	119,1
82,3	5,8	4,0	92,1	119,1

<b>Body Weight</b> <b>BW in kg</b>	<b>Add. Weight</b> <b>AW in kg</b>	<b>Race Clothing</b> <b>RC in kg</b>	<b>Total Weight</b> <b>TW in kg</b>	<b>Total</b> <b>with Sled</b>
82,4	5,7	4,0	92,1	119,1
82,5	5,6	4,0	92,1	119,1
82,6	5,6	4,0	92,2	119,2
82,7	5,5	4,0	92,2	119,2
82,8	5,4	4,0	92,2	119,2
82,9	5,3	4,0	92,2	119,2
<b>83,0</b>	<b>5,3</b>	<b>4,0</b>	<b>92,3</b>	<b>119,3</b>
83,1	5,2	4,0	92,3	119,3
83,2	5,1	4,0	92,3	119,3
83,3	5,0	4,0	92,3	119,3
83,4	5,0	4,0	92,4	119,4
83,5	4,9	4,0	92,4	119,4
83,6	4,8	4,0	92,4	119,4
83,7	4,7	4,0	92,4	119,4
83,8	4,7	4,0	92,5	119,5
83,9	4,6	4,0	92,5	119,5
<b>84,0</b>	<b>4,5</b>	<b>4,0</b>	<b>92,5</b>	<b>119,5</b>
84,1	4,4	4,0	92,5	119,5
84,2	4,4	4,0	92,6	119,6
84,3	4,3	4,0	92,6	119,6
84,4	4,2	4,0	92,6	119,6
84,5	4,1	4,0	92,6	119,6
84,6	4,1	4,0	92,7	119,7
84,7	4,0	4,0	92,7	119,7
84,8	3,9	4,0	92,7	119,7
84,9	3,8	4,0	92,7	119,7
<b>85,0</b>	<b>3,8</b>	<b>4,0</b>	<b>92,8</b>	<b>119,8</b>
85,1	3,7	4,0	92,8	119,8
85,2	3,6	4,0	92,8	119,8
85,3	3,5	4,0	92,8	119,8
85,4	3,5	4,0	92,9	119,9
85,5	3,4	4,0	92,9	119,9

<b>Body Weight</b> <b>BW in kg</b>	<b>Add. Weight</b> <b>AW in kg</b>	<b>Race Clothing</b> <b>RC in kg</b>	<b>Total Weight</b> <b>TW in kg</b>	<b>Total</b> <b>with Sled</b>
85,6	3,3	4,0	92,9	119,9
85,7	3,2	4,0	92,9	119,9
85,8	3,2	4,0	93,0	120,0
85,9	3,1	4,0	93,0	120,0
<b>86,0</b>	<b>3,0</b>	<b>4,0</b>	<b>93,0</b>	<b>120,0</b>
86,1	2,9	4,0	93,0	120,0
86,2	2,9	4,0	93,1	120,1
86,3	2,8	4,0	93,1	120,1
86,4	2,7	4,0	93,1	120,1
86,5	2,6	4,0	93,1	120,1
86,6	2,6	4,0	93,2	120,2
86,7	2,5	4,0	93,2	120,2
86,8	2,4	4,0	93,2	120,2
86,9	2,3	4,0	93,2	120,2
<b>87,0</b>	<b>2,3</b>	<b>4,0</b>	<b>93,3</b>	<b>120,3</b>
87,1	2,2	4,0	93,3	120,3
87,2	2,1	4,0	93,3	120,3
87,3	2,0	4,0	93,3	120,3
87,4	2,0	4,0	93,4	120,4
87,5	1,9	4,0	93,4	120,4
87,6	1,8	4,0	93,4	120,4
87,7	1,7	4,0	93,4	120,4
87,8	1,7	4,0	93,5	120,5
87,9	1,6	4,0	93,5	120,5
<b>88,0</b>	<b>1,5</b>	<b>4,0</b>	<b>93,5</b>	<b>120,5</b>
88,1	1,4	4,0	93,5	120,5
88,2	1,4	4,0	93,6	120,6
88,3	1,3	4,0	93,6	120,6
88,4	1,2	4,0	93,6	120,6
88,5	1,1	4,0	93,6	120,6
88,6	1,1	4,0	93,7	120,7
88,7	1,0	4,0	93,7	120,7

<b>Body Weight</b> <b>BW in kg</b>	<b>Add. Weight</b> <b>AW in kg</b>	<b>Race Clothing</b> <b>RC in kg</b>	<b>Total Weight</b> <b>TW in kg</b>	<b>Total</b> <b>with Sled</b>
88,8	0,9	4,0	93,7	120,7
88,9	0,8	4,0	93,7	120,7
<b>89,0</b>	<b>0,8</b>	<b>4,0</b>	<b>93,8</b>	<b>120,8</b>
89,1	0,7	4,0	93,8	120,8
89,2	0,6	4,0	93,8	120,8
89,3	0,5	4,0	93,8	120,8
89,4	0,4	4,0	93,9	120,9
89,5	0,4	4,0	93,9	120,9
89,6	0,3	4,0	93,9	120,9
89,7	0,2	4,0	93,9	120,9
89,8	0,2	4,0	94,0	121,0
89,9	0,1	4,0	94,0	121,0
<b>90,0</b>	<b>0,0</b>	<b>4,0</b>	<b>94,0</b>	<b>121,0</b>

**Juniors (men):**

AW = 75% of the difference between 90 kg and BW (max. 13 kg)

TW = BW + AW + 4 kg RC

<b>Body Weight</b>	<b>Additional Weight</b>	<b>Race Clothing</b>	<b>Total Weight</b>	<b>Total</b>
<b>BW in kg</b>	<b>AW in kg</b>	<b>RC in kg</b>	<b>TW in kg</b>	<b>with Sled</b>
72,7	13,0	4,0	89,7	112,7
72,8	12,9	4,0	89,7	112,7
72,9	12,8	4,0	89,7	112,7
<b>73,0</b>	<b>12,8</b>	<b>4,0</b>	<b>89,8</b>	<b>112,8</b>
73,1	12,7	4,0	89,8	112,8
73,2	12,6	4,0	89,8	112,8
73,3	12,5	4,0	89,8	112,8
73,4	12,5	4,0	89,9	112,9
73,5	12,4	4,0	89,9	112,9
73,6	12,3	4,0	89,9	112,9
73,7	12,2	4,0	89,9	112,9
73,8	12,2	4,0	90,0	113,0
73,9	12,1	4,0	90,0	113,0
<b>74,0</b>	<b>12,0</b>	<b>4,0</b>	<b>90,0</b>	<b>113,0</b>
74,1	11,9	4,0	90,0	113,0
74,2	11,9	4,0	90,1	113,1
74,3	11,8	4,0	90,1	113,1
74,4	11,7	4,0	90,1	113,1
74,5	11,6	4,0	90,1	113,1
74,6	11,6	4,0	90,2	113,2
74,7	11,5	4,0	90,2	113,2
74,8	11,4	4,0	90,2	113,2
74,9	11,3	4,0	90,2	113,2
<b>75,0</b>	<b>11,3</b>	<b>4,0</b>	<b>90,3</b>	<b>113,3</b>
75,1	11,2	4,0	90,3	113,3
75,2	11,1	4,0	90,3	113,3

<b>Body Weight</b> <b>BW in kg</b>	<b>Additional Weight</b> <b>AW in kg</b>	<b>Race Clothing</b> <b>RC in kg</b>	<b>Total Weight</b> <b>TW in kg</b>	<b>Total</b> <b>with Sled</b>
75,3	11,0	4,0	90,3	113,3
75,4	11,0	4,0	90,4	113,4
75,5	10,9	4,0	90,4	113,4
75,6	10,8	4,0	90,4	113,4
75,7	10,7	4,0	90,4	113,4
75,8	10,7	4,0	90,5	113,5
75,9	10,6	4,0	90,5	113,5
<b>76,0</b>	<b>10,5</b>	<b>4,0</b>	<b>90,5</b>	<b>113,5</b>
76,1	10,4	4,0	90,5	113,5
76,2	10,4	4,0	90,6	113,6
76,3	10,3	4,0	90,6	113,6
76,4	10,2	4,0	90,6	113,6
76,5	10,1	4,0	90,6	113,6
76,6	10,1	4,0	90,7	113,7
76,7	10,0	4,0	90,7	113,7
76,8	9,9	4,0	90,7	113,7
76,9	9,8	4,0	90,7	113,7
<b>77,0</b>	<b>9,8</b>	<b>4,0</b>	<b>90,8</b>	<b>113,8</b>
77,1	9,7	4,0	90,8	113,8
77,2	9,6	4,0	90,8	113,8
77,3	9,5	4,0	90,8	113,8
77,4	9,5	4,0	90,9	113,9
77,5	9,4	4,0	90,9	113,9
77,6	9,3	4,0	90,9	113,9
77,7	9,2	4,0	90,9	113,9
77,8	9,2	4,0	91,0	114,0
77,9	9,1	4,0	91,0	114,0
<b>78,0</b>	<b>9,0</b>	<b>4,0</b>	<b>91,0</b>	<b>114,0</b>
78,1	8,9	4,0	91,0	114,0
78,2	8,9	4,0	91,1	114,1
78,3	8,8	4,0	91,1	114,1
78,4	8,7	4,0	91,1	114,1



<b>Body Weight</b> <b>BW in kg</b>	<b>Additional Weight</b> <b>AW in kg</b>	<b>Race Clothing</b> <b>RC in kg</b>	<b>Total Weight</b> <b>TW in kg</b>	<b>Total</b> <b>with Sled</b>
78,5	8,6	4,0	91,1	114,1
78,6	8,6	4,0	91,2	114,2
78,7	8,5	4,0	91,2	114,2
78,8	8,4	4,0	91,2	114,2
78,9	8,3	4,0	91,2	114,2
<b>79,0</b>	<b>8,3</b>	<b>4,0</b>	<b>91,3</b>	<b>114,3</b>
79,1	8,2	4,0	91,3	114,3
79,2	8,1	4,0	91,3	114,3
79,3	8,0	4,0	91,3	114,3
79,4	8,0	4,0	91,4	114,4
79,5	7,9	4,0	91,4	114,4
79,6	7,8	4,0	91,4	114,4
79,7	7,7	4,0	91,4	114,4
79,8	7,7	4,0	91,5	114,5
79,9	7,6	4,0	91,5	114,5
<b>80,0</b>	<b>7,5</b>	<b>4,0</b>	<b>91,5</b>	<b>114,5</b>
80,1	7,4	4,0	91,5	114,5
80,2	7,4	4,0	91,6	114,6
80,3	7,3	4,0	91,6	114,6
80,4	7,2	4,0	91,6	114,6
80,5	7,1	4,0	91,6	114,6
80,6	7,1	4,0	91,7	114,7
80,7	7,0	4,0	91,7	114,7
80,8	6,9	4,0	91,7	114,7
80,9	6,8	4,0	91,7	114,7
<b>81,0</b>	<b>6,8</b>	<b>4,0</b>	<b>91,8</b>	<b>114,8</b>
81,1	6,7	4,0	91,8	114,8
81,2	6,6	4,0	91,8	114,8
81,3	6,5	4,0	91,8	114,8
81,4	6,5	4,0	91,9	114,9
81,5	6,4	4,0	91,9	114,9
81,6	6,3	4,0	91,9	114,9

<b>Body Weight</b> <b>BW in kg</b>	<b>Additional Weight</b> <b>AW in kg</b>	<b>Race Clothing</b> <b>RC in kg</b>	<b>Total Weight</b> <b>TW in kg</b>	<b>Total</b> <b>with Sled</b>
81,7	6,2	4,0	91,9	114,9
81,8	6,2	4,0	92,0	115,0
81,9	6,1	4,0	92,0	115,0
<b>82,0</b>	<b>6,0</b>	<b>4,0</b>	<b>92,0</b>	<b>115,0</b>
82,1	5,9	4,0	92,0	115,0
82,2	5,9	4,0	92,1	115,1
82,3	5,8	4,0	92,1	115,1
82,4	5,7	4,0	92,1	115,1
82,5	5,6	4,0	92,1	115,1
82,6	5,6	4,0	92,2	115,2
82,7	5,5	4,0	92,2	115,2
82,8	5,4	4,0	92,2	115,2
82,9	5,3	4,0	92,2	115,2
<b>83,0</b>	<b>5,3</b>	<b>4,0</b>	<b>92,3</b>	<b>115,3</b>
83,1	5,2	4,0	92,3	115,3
83,2	5,1	4,0	92,3	115,3
83,3	5,0	4,0	92,3	115,3
83,4	5,0	4,0	92,4	115,4
83,5	4,9	4,0	92,4	115,4
83,6	4,8	4,0	92,4	115,4
83,7	4,7	4,0	92,4	115,4
83,8	4,7	4,0	92,5	115,5
83,9	4,6	4,0	92,5	115,5
<b>84,0</b>	<b>4,5</b>	<b>4,0</b>	<b>92,5</b>	<b>115,5</b>
84,1	4,4	4,0	92,5	115,5
84,2	4,4	4,0	92,6	115,6
84,3	4,3	4,0	92,6	115,6
84,4	4,2	4,0	92,6	115,6
84,5	4,1	4,0	92,6	115,6
84,6	4,1	4,0	92,7	115,7
84,7	4,0	4,0	92,7	115,7
84,8	3,9	4,0	92,7	115,7

<b>Body Weight</b> <b>BW in kg</b>	<b>Additional Weight</b> <b>AW in kg</b>	<b>Race Clothing</b> <b>RC in kg</b>	<b>Total Weight</b> <b>TW in kg</b>	<b>Total</b> <b>with Sled</b>
84,9	3,8	4,0	92,7	115,7
<b>85,0</b>	<b>3,8</b>	<b>4,0</b>	<b>92,8</b>	<b>115,8</b>
85,1	3,7	4,0	92,8	115,8
85,2	3,6	4,0	92,8	115,8
85,3	3,5	4,0	92,8	115,8
85,4	3,5	4,0	92,9	115,9
85,5	3,4	4,0	92,9	115,9
85,6	3,3	4,0	92,9	115,9
85,7	3,2	4,0	92,9	115,9
85,8	3,2	4,0	93,0	116,0
85,9	3,1	4,0	93,0	116,0
<b>86,0</b>	<b>3,0</b>	<b>4,0</b>	<b>93,0</b>	<b>116,0</b>
86,1	2,9	4,0	93,0	116,0
86,2	2,9	4,0	93,1	116,1
86,3	2,8	4,0	93,1	116,1
86,4	2,7	4,0	93,1	116,1
86,5	2,6	4,0	93,1	116,1
86,6	2,6	4,0	93,2	116,2
86,7	2,5	4,0	93,2	116,2
86,8	2,4	4,0	93,2	116,2
86,9	2,3	4,0	93,2	116,2
<b>87,0</b>	<b>2,3</b>	<b>4,0</b>	<b>93,3</b>	<b>116,3</b>
87,1	2,2	4,0	93,3	116,3
87,2	2,1	4,0	93,3	116,3
87,3	2,0	4,0	93,3	116,3
87,4	2,0	4,0	93,4	116,4
87,5	1,9	4,0	93,4	116,4
87,6	1,8	4,0	93,4	116,4
87,7	1,7	4,0	93,4	116,4
87,8	1,7	4,0	93,5	116,5
87,9	1,6	4,0	93,5	116,5
<b>88,0</b>	<b>1,5</b>	<b>4,0</b>	<b>93,5</b>	<b>116,5</b>

<b>Body Weight</b> <b>BW in kg</b>	<b>Additional Weight</b> <b>AW in kg</b>	<b>Race Clothing</b> <b>RC in kg</b>	<b>Total Weight</b> <b>TW in kg</b>	<b>Total</b> <b>with Sled</b>
88,1	1,4	4,0	93,5	116,5
88,2	1,4	4,0	93,6	116,6
88,3	1,3	4,0	93,6	116,6
88,4	1,2	4,0	93,6	116,6
88,5	1,1	4,0	93,6	116,6
88,6	1,1	4,0	93,7	116,7
88,7	1,0	4,0	93,7	116,7
88,8	0,9	4,0	93,7	116,7
88,9	0,8	4,0	93,7	116,7
<b>89,0</b>	<b>0,8</b>	<b>4,0</b>	<b>93,8</b>	<b>116,8</b>
89,1	0,7	4,0	93,8	116,8
89,2	0,6	4,0	93,8	116,8
89,3	0,5	4,0	93,8	116,8
89,4	0,5	4,0	93,9	116,9
89,5	0,4	4,0	93,9	116,9
89,6	0,3	4,0	93,9	116,9
89,7	0,2	4,0	93,9	116,9
89,8	0,2	4,0	94,0	117,0
89,9	0,1	4,0	94,0	117,0
<b>90,0</b>	<b>0,0</b>	<b>4,0</b>	<b>94,0</b>	<b>117,0</b>

**Juniors doubles:**

AW = 50% of the difference between 90 kg and BW (max. 10 kg)

TW = BW + AW + 4 kg RC

<b>Body Weight BW in kg</b>	<b>Additional Weight AW in kg</b>	<b>Race Clothing RC in kg</b>	<b>Total Weight TW in kg</b>	<b>Total with Sled</b>
<b>70,0</b>	<b>10,0</b>	<b>4,0</b>	<b>84,0</b>	<b>111,0</b>
70,1	9,9	4,0	84,0	111,0
70,2	9,9	4,0	84,1	111,1
70,3	9,8	4,0	84,1	111,1
70,4	9,8	4,0	84,2	111,2
70,5	9,7	4,0	84,2	111,2
70,6	9,7	4,0	84,3	111,3
70,7	9,6	4,0	84,3	111,3
70,8	9,6	4,0	84,4	111,4
70,9	9,5	4,0	84,4	111,4
<b>71,0</b>	<b>9,5</b>	<b>4,0</b>	<b>84,5</b>	<b>111,5</b>
71,1	9,4	4,0	84,5	111,5
71,2	9,4	4,0	84,6	111,6
71,3	9,3	4,0	84,6	111,6
71,4	9,3	4,0	84,7	111,7
71,5	9,2	4,0	84,7	111,7
71,6	9,2	4,0	84,8	111,8
71,7	9,1	4,0	84,8	111,8
71,8	9,1	4,0	84,9	111,9
71,9	9,0	4,0	84,9	111,9
<b>72,0</b>	<b>9,0</b>	<b>4,0</b>	<b>85,0</b>	<b>112,0</b>
72,1	8,9	4,0	85,0	112,0
72,2	8,9	4,0	85,1	112,1
72,3	8,8	4,0	85,1	112,1
72,4	8,8	4,0	85,2	112,2
72,5	8,7	4,0	85,2	112,2
72,6	8,7	4,0	85,3	112,3
72,7	8,6	4,0	85,3	112,3

<b>Body Weight</b> <b>BW in kg</b>	<b>Additional Weight</b> <b>AW in kg</b>	<b>Race Clothing</b> <b>RC in kg</b>	<b>Total Weight</b> <b>TW in kg</b>	<b>Total</b> <b>with Sled</b>
72,8	8,6	4,0	85,4	112,4
72,9	8,5	4,0	85,4	112,4
<b>73,0</b>	<b>8,5</b>	<b>4,0</b>	<b>85,5</b>	<b>112,5</b>
73,1	8,4	4,0	85,5	112,5
73,2	8,4	4,0	85,6	112,6
73,3	8,3	4,0	85,6	112,6
73,4	8,3	4,0	85,7	112,7
73,5	8,2	4,0	85,7	112,7
73,6	8,2	4,0	85,8	112,8
73,7	8,1	4,0	85,8	112,8
73,8	8,1	4,0	85,9	112,9
73,9	8,0	4,0	85,9	112,9
<b>74,0</b>	<b>8,0</b>	<b>4,0</b>	<b>86,0</b>	<b>113,0</b>
74,1	7,9	4,0	86,0	113,0
74,2	7,9	4,0	86,1	113,1
74,3	7,8	4,0	86,1	113,1
74,4	7,8	4,0	86,2	113,2
74,5	7,7	4,0	86,2	113,2
74,6	7,7	4,0	86,3	113,3
74,7	7,6	4,0	86,3	113,3
74,8	7,6	4,0	86,4	113,4
74,9	7,5	4,0	86,4	113,4
<b>75,0</b>	<b>7,5</b>	<b>4,0</b>	<b>86,5</b>	<b>113,5</b>
75,1	7,4	4,0	86,5	113,5
75,2	7,4	4,0	86,6	113,6
75,3	7,3	4,0	86,6	113,6
75,4	7,3	4,0	86,7	113,7
75,5	7,2	4,0	86,7	113,7
75,6	7,2	4,0	86,8	113,8
75,7	7,1	4,0	86,8	113,8
75,8	7,1	4,0	86,9	113,9
75,9	7,0	4,0	86,9	113,9

<b>Body Weight</b> <b>BW in kg</b>	<b>Additional Weight</b> <b>AW in kg</b>	<b>Race Clothing</b> <b>RC in kg</b>	<b>Total Weight</b> <b>TW in kg</b>	<b>Total</b> <b>with Sled</b>
<b>76,0</b>	<b>7,0</b>	<b>4,0</b>	<b>87,0</b>	<b>114,0</b>
76,1	6,9	4,0	87,0	114,0
76,2	6,9	4,0	87,1	114,1
76,3	6,8	4,0	87,1	114,1
76,4	6,8	4,0	87,2	114,2
76,5	6,7	4,0	87,2	114,2
76,6	6,7	4,0	87,3	114,3
76,7	6,6	4,0	87,3	114,3
76,8	6,6	4,0	87,4	114,4
76,9	6,5	4,0	87,4	114,4
<b>77,0</b>	<b>6,5</b>	<b>4,0</b>	<b>87,5</b>	<b>114,5</b>
77,1	6,4	4,0	87,5	114,5
77,2	6,4	4,0	87,6	114,6
77,3	6,3	4,0	87,6	114,6
77,4	6,3	4,0	87,7	114,7
77,5	6,2	4,0	87,7	114,7
77,6	6,2	4,0	87,8	114,8
77,7	6,1	4,0	87,8	114,8
77,8	6,1	4,0	87,9	114,9
77,9	6,0	4,0	87,9	114,9
<b>78,0</b>	<b>6,0</b>	<b>4,0</b>	<b>88,0</b>	<b>115,0</b>
78,1	5,9	4,0	88,0	115,0
78,2	5,9	4,0	88,1	115,1
78,3	5,8	4,0	88,1	115,1
78,4	5,8	4,0	88,2	115,2
78,5	5,7	4,0	88,2	115,2
78,6	5,7	4,0	88,3	115,3
78,7	5,6	4,0	88,3	115,3
78,8	5,6	4,0	88,4	115,4
78,9	5,5	4,0	88,4	115,4
<b>79,0</b>	<b>5,5</b>	<b>4,0</b>	<b>88,5</b>	<b>115,5</b>
79,1	5,4	4,0	88,5	115,5

<b>Body Weight</b> <b>BW in kg</b>	<b>Additional Weight</b> <b>AW in kg</b>	<b>Race Clothing</b> <b>RC in kg</b>	<b>Total Weight</b> <b>TW in kg</b>	<b>Total</b> <b>with Sled</b>
79,2	5,4	4,0	88,6	115,6
79,3	5,3	4,0	88,6	115,6
79,4	5,3	4,0	88,7	115,7
79,5	5,2	4,0	88,7	115,7
79,6	5,2	4,0	88,8	115,8
79,7	5,1	4,0	88,8	115,8
79,8	5,1	4,0	88,9	115,9
79,9	5,0	4,0	88,9	115,9
<b>80,0</b>	<b>5,0</b>	<b>4,0</b>	<b>89,0</b>	<b>116,0</b>
80,1	4,9	4,0	89,0	116,0
80,2	4,9	4,0	89,1	116,1
80,3	4,8	4,0	89,1	116,1
80,4	4,8	4,0	89,2	116,2
80,5	4,7	4,0	89,2	116,2
80,6	4,7	4,0	89,3	116,3
80,7	4,6	4,0	89,3	116,3
80,8	4,6	4,0	89,4	116,4
80,9	4,5	4,0	89,4	116,4
<b>81,0</b>	<b>4,5</b>	<b>4,0</b>	<b>89,5</b>	<b>116,5</b>
81,1	4,4	4,0	89,5	116,5
81,2	4,4	4,0	89,6	116,6
81,3	4,3	4,0	89,6	116,6
81,4	4,3	4,0	89,7	116,7
81,5	4,2	4,0	89,7	116,7
81,6	4,2	4,0	89,8	116,8
81,7	4,1	4,0	89,8	116,8
81,8	4,1	4,0	89,9	116,9
81,9	4,0	4,0	89,9	116,9
<b>82,0</b>	<b>4,0</b>	<b>4,0</b>	<b>90,0</b>	<b>117,0</b>
82,1	3,9	4,0	90,0	117,0
82,2	3,9	4,0	90,1	117,1
82,3	3,8	4,0	90,1	117,1



<b>Body Weight</b> <b>BW in kg</b>	<b>Additional Weight</b> <b>AW in kg</b>	<b>Race Clothing</b> <b>RC in kg</b>	<b>Total Weight</b> <b>TW in kg</b>	<b>Total</b> <b>with Sled</b>
82,4	3,8	4,0	90,2	117,2
82,5	3,7	4,0	90,2	117,2
82,6	3,7	4,0	90,3	117,3
82,7	3,6	4,0	90,3	117,3
82,8	3,6	4,0	90,4	117,4
82,9	3,5	4,0	90,4	117,4
<b>83,0</b>	<b>3,5</b>	<b>4,0</b>	<b>90,5</b>	<b>117,5</b>
83,1	3,4	4,0	90,5	117,5
83,2	3,4	4,0	90,6	117,6
83,3	3,3	4,0	90,6	117,6
83,4	3,3	4,0	90,7	117,7
83,5	3,2	4,0	90,7	117,7
83,6	3,2	4,0	90,8	117,8
83,7	3,1	4,0	90,8	117,8
83,8	3,1	4,0	90,9	117,9
83,9	3,0	4,0	90,9	117,9
<b>84,0</b>	<b>3,0</b>	<b>4,0</b>	<b>91,0</b>	<b>118,0</b>
84,1	2,9	4,0	91,0	118,0
84,2	2,9	4,0	91,1	118,1
84,3	2,8	4,0	91,1	118,1
84,4	2,8	4,0	91,2	118,2
84,5	2,7	4,0	91,2	118,2
84,6	2,7	4,0	91,3	118,3
84,7	2,6	4,0	91,3	118,3
84,8	2,6	4,0	91,4	118,4
84,9	2,5	4,0	91,4	118,4
<b>85,0</b>	<b>2,5</b>	<b>4,0</b>	<b>91,5</b>	<b>118,5</b>
85,1	2,4	4,0	91,5	118,5
85,2	2,4	4,0	91,6	118,6
85,3	2,3	4,0	91,6	118,6
85,4	2,3	4,0	91,7	118,7
85,5	2,2	4,0	91,7	118,7

<b>Body Weight</b> <b>BW in kg</b>	<b>Additional Weight</b> <b>AW in kg</b>	<b>Race Clothing</b> <b>RC in kg</b>	<b>Total Weight</b> <b>TW in kg</b>	<b>Total</b> <b>with Sled</b>
85,6	2,2	4,0	91,8	118,8
85,7	2,1	4,0	91,8	118,8
85,8	2,1	4,0	91,9	118,9
85,9	2,0	4,0	91,9	118,9
<b>86,0</b>	<b>2,0</b>	<b>4,0</b>	<b>92,0</b>	<b>119,0</b>
86,1	1,9	4,0	92,0	119,0
86,2	1,9	4,0	92,1	119,1
86,3	1,8	4,0	92,1	119,1
86,4	1,8	4,0	92,2	119,2
86,5	1,7	4,0	92,2	119,2
86,6	1,7	4,0	92,3	119,3
86,7	1,6	4,0	92,3	119,3
86,8	1,6	4,0	92,4	119,4
86,9	1,5	4,0	92,4	119,4
<b>87,0</b>	<b>1,5</b>	<b>4,0</b>	<b>92,5</b>	<b>119,5</b>
87,1	1,4	4,0	92,5	119,5
87,2	1,4	4,0	92,6	119,6
87,3	1,3	4,0	92,6	119,6
87,4	1,3	4,0	92,7	119,7
87,5	1,2	4,0	92,7	119,7
87,6	1,2	4,0	92,8	119,8
87,7	1,1	4,0	92,8	119,8
87,8	1,1	4,0	92,9	119,9
87,9	1,0	4,0	92,9	119,9
<b>88,0</b>	<b>1,0</b>	<b>4,0</b>	<b>93,0</b>	<b>120,0</b>
88,1	0,9	4,0	93,0	120,0
88,2	0,9	4,0	93,1	120,1
88,3	0,8	4,0	93,1	120,1
88,4	0,8	4,0	93,2	120,2
88,5	0,7	4,0	93,2	120,2
88,6	0,7	4,0	93,3	120,3
88,7	0,6	4,0	93,3	120,3

<b>Body Weight</b> <b>BW in kg</b>	<b>Additional Weight</b> <b>AW in kg</b>	<b>Race Clothing</b> <b>RC in kg</b>	<b>Total Weight</b> <b>TW in kg</b>	<b>Total</b> <b>with Sled</b>
88,8	0,6	4,0	93,4	120,4
88,9	0,5	4,0	93,4	120,4
<b>89,0</b>	<b>0,5</b>	<b>4,0</b>	<b>93,5</b>	<b>120,5</b>
89,1	0,4	4,0	93,5	120,5
89,2	0,4	4,0	93,6	120,6
89,3	0,3	4,0	93,6	120,6
89,4	0,3	4,0	93,7	120,7
89,5	0,2	4,0	93,7	120,7
89,6	0,2	4,0	93,8	120,8
89,7	0,1	4,0	93,8	120,8
89,8	0,1	4,0	93,9	120,9
89,9	0,0	4,0	93,9	120,9
<b>90,0</b>	<b>0,0</b>	<b>4,0</b>	<b>94,0</b>	<b>121,0</b>

**Juniors (women), Youth A men:**

AW = 75% of the difference between 75 kg and BW (max. 10 kg)

TW = BW + AW + 4 kg RC

<b>Body Weight BW in kg</b>	<b>Additional Weight AW in kg</b>	<b>Race Clothing RC in kg</b>	<b>Total Weight TW in kg</b>	<b>Total with Sled</b>
61,7	10,0	4,0	75,7	98,7
61,8	9,9	4,0	75,7	98,7
61,9	9,8	4,0	75,7	98,7
<b>62,0</b>	<b>9,8</b>	<b>4,0</b>	<b>75,8</b>	<b>98,8</b>
62,1	9,7	4,0	75,8	98,8
62,2	9,6	4,0	75,8	98,8
62,3	9,5	4,0	75,8	98,8
62,4	9,5	4,0	75,9	98,9
62,5	9,4	4,0	75,9	98,9
62,6	9,3	4,0	75,9	98,9
62,7	9,2	4,0	75,9	98,9
62,8	9,2	4,0	76,0	99,0
62,9	9,1	4,0	76,0	99,0
<b>63,0</b>	<b>9,0</b>	<b>4,0</b>	<b>76,0</b>	<b>99,0</b>
63,1	8,9	4,0	76,0	99,0
63,2	8,9	4,0	76,1	99,1
63,3	8,8	4,0	76,1	99,1
63,4	8,7	4,0	76,1	99,1
63,5	8,6	4,0	76,1	99,1
63,6	8,6	4,0	76,2	99,2
63,7	8,5	4,0	76,2	99,2
63,8	8,4	4,0	76,2	99,2
63,9	8,3	4,0	76,2	99,2
<b>64,0</b>	<b>8,3</b>	<b>4,0</b>	<b>76,3</b>	<b>99,3</b>
64,1	8,2	4,0	76,3	99,3
64,2	8,1	4,0	76,3	99,3
64,3	8,0	4,0	76,3	99,3
64,4	8,0	4,0	76,4	99,4

<b>Body Weight</b> <b>BW in kg</b>	<b>Add. Weight</b> <b>AW in kg</b>	<b>Race Clothing</b> <b>RC in kg</b>	<b>Total Weight</b> <b>TW in kg</b>	<b>Total</b> <b>with Sled</b>
64,5	7,9	4,0	76,4	99,4
64,6	7,8	4,0	76,4	99,4
64,7	7,7	4,0	76,4	99,4
64,8	7,7	4,0	76,5	99,5
64,9	7,6	4,0	76,5	99,5
<b>65,0</b>	<b>7,5</b>	<b>4,0</b>	<b>76,5</b>	<b>99,5</b>
65,1	7,4	4,0	76,5	99,5
65,2	7,4	4,0	76,6	99,6
65,3	7,3	4,0	76,6	99,6
65,4	7,2	4,0	76,6	99,6
65,5	7,1	4,0	76,6	99,6
65,6	7,1	4,0	76,7	99,7
65,7	7,0	4,0	76,7	99,7
65,8	6,9	4,0	76,7	99,7
65,9	6,8	4,0	76,7	99,7
<b>66,0</b>	<b>6,8</b>	<b>4,0</b>	<b>76,8</b>	<b>99,8</b>
66,1	6,7	4,0	76,8	99,8
66,2	6,6	4,0	76,8	99,8
66,3	6,5	4,0	76,8	99,8
66,4	6,5	4,0	76,9	99,9
66,5	6,4	4,0	76,9	99,9
66,6	6,3	4,0	76,9	99,9
66,7	6,2	4,0	76,9	99,9
66,8	6,2	4,0	77,0	100,0
66,9	6,1	4,0	77,0	100,0
<b>67,0</b>	<b>6,0</b>	<b>4,0</b>	<b>77,0</b>	<b>100,0</b>
67,1	5,9	4,0	77,0	100,0
67,2	5,9	4,0	77,1	100,1
67,3	5,8	4,0	77,1	100,1
67,4	5,7	4,0	77,1	100,1
67,5	5,6	4,0	77,1	100,1
67,6	5,6	4,0	77,2	100,2
67,7	5,5	4,0	77,2	100,2

<b>Body Weight</b> <b>BW in kg</b>	<b>Add. Weight</b> <b>AW in kg</b>	<b>Race Clothing</b> <b>RC in kg</b>	<b>Total Weight</b> <b>TW in kg</b>	<b>Total</b> <b>with Sled</b>
67,8	5,4	4,0	77,2	100,2
67,9	5,3	4,0	77,2	100,2
<b>68,0</b>	<b>5,3</b>	<b>4,0</b>	<b>77,3</b>	<b>100,3</b>
68,1	5,2	4,0	77,3	100,3
68,2	5,1	4,0	77,3	100,3
68,3	5,0	4,0	77,3	100,3
68,4	5,0	4,0	77,4	100,4
68,5	4,9	4,0	77,4	100,4
68,6	4,8	4,0	77,4	100,4
68,7	4,7	4,0	77,4	100,4
68,8	4,7	4,0	77,5	100,5
68,9	4,6	4,0	77,5	100,5
<b>69,0</b>	<b>4,5</b>	<b>4,0</b>	<b>77,5</b>	<b>100,5</b>
69,1	4,4	4,0	77,5	100,5
69,2	4,4	4,0	77,6	100,6
69,3	4,3	4,0	77,6	100,6
69,4	4,2	4,0	77,6	100,6
69,5	4,1	4,0	77,6	100,6
69,6	4,1	4,0	77,7	100,7
69,7	4,0	4,0	77,7	100,7
69,8	3,9	4,0	77,7	100,7
69,9	3,8	4,0	77,7	100,7
<b>70,0</b>	<b>3,8</b>	<b>4,0</b>	<b>77,8</b>	<b>100,8</b>
70,1	3,7	4,0	77,8	100,8
70,2	3,6	4,0	77,8	100,8
70,3	3,5	4,0	77,8	100,8
70,4	3,5	4,0	77,9	100,9
70,5	3,4	4,0	77,9	100,9
70,6	3,3	4,0	77,9	100,9
70,7	3,2	4,0	77,9	100,9
70,8	3,2	4,0	78,0	101,0
70,9	3,1	4,0	78,0	101,0
<b>71,0</b>	<b>3,0</b>	<b>4,0</b>	<b>78,0</b>	<b>101,0</b>

<b>Body Weight</b>	<b>Additional Weight</b>	<b>Race Clothing</b>	<b>Total Weight</b>	<b>Total</b>
<b>BW in kg</b>	<b>AW in kg</b>	<b>RC in kg</b>	<b>TW in kg</b>	<b>with Sled</b>
71,1	2,9	4,0	78,0	101,0
71,2	2,9	4,0	78,1	101,1
71,3	2,8	4,0	78,1	101,1
71,4	2,7	4,0	78,1	101,1
71,5	2,6	4,0	78,1	101,1
71,6	2,6	4,0	78,2	101,2
71,7	2,5	4,0	78,2	101,2
71,8	2,4	4,0	78,2	101,2
71,9	2,3	4,0	78,2	101,2
<b>72,0</b>	<b>2,3</b>	<b>4,0</b>	<b>78,3</b>	<b>101,3</b>
72,1	2,2	4,0	78,3	101,3
72,2	2,1	4,0	78,3	101,3
72,3	2,0	4,0	78,3	101,3
72,4	2,0	4,0	78,4	101,4
72,5	1,9	4,0	78,4	101,4
72,6	1,8	4,0	78,4	101,4
72,7	1,7	4,0	78,4	101,4
72,8	1,7	4,0	78,5	101,5
72,9	1,6	4,0	78,5	101,5
<b>73,0</b>	<b>1,5</b>	<b>4,0</b>	<b>78,5</b>	<b>101,5</b>
73,1	1,4	4,0	78,5	101,5
73,2	1,4	4,0	78,6	101,6
73,3	1,3	4,0	78,6	101,6
73,4	1,2	4,0	78,6	101,6
73,5	1,1	4,0	78,6	101,6
73,6	1,1	4,0	78,7	101,7
73,7	1,0	4,0	78,7	101,7
73,8	0,9	4,0	78,7	101,7
73,9	0,8	4,0	78,7	101,7
<b>74,0</b>	<b>0,8</b>	<b>4,0</b>	<b>78,8</b>	<b>101,8</b>
74,1	0,7	4,0	78,8	101,8
74,2	0,6	4,0	78,8	101,8

<b>Body Weight</b> <b>BW in kg</b>	<b>Additional Weight</b> <b>AW in kg</b>	<b>Race Clothing</b> <b>RC in kg</b>	<b>Total Weight</b> <b>TW in kg</b>	<b>Total</b> <b>with Sled</b>
74,3	0,5	4,0	78,8	101,8
74,4	0,5	4,0	78,9	101,9
74,5	0,4	4,0	78,9	101,9
74,6	0,3	4,0	78,9	101,9
74,7	0,2	4,0	78,9	101,9
74,8	0,2	4,0	79,0	102,0
74,9	0,1	4,0	79,0	102,0
<b>75,0</b>	<b>0,0</b>	<b>4,0</b>	<b>79,0</b>	<b>102,0</b>



**Youth A women:**

AW = 50% of the difference between between 70 kg and BW (max. 8 kg)

TW = BW + AW + 4 kg RC

<b>Body Weight</b>	<b>Additional Weight</b>	<b>Race Clothing</b>	<b>Total Weight</b>	<b>Total</b>
<b>BW in kg</b>	<b>AW in kg</b>	<b>RC in kg</b>	<b>TW in kg</b>	<b>with Sled</b>
<b>54,0</b>	<b>8,0</b>	<b>4,0</b>	<b>66,0</b>	<b>89,0</b>
54,1	8,0	4,0	66,1	89,1
54,2	7,9	4,0	66,1	89,1
54,3	7,9	4,0	66,2	89,2
54,4	7,8	4,0	66,2	89,2
54,5	7,8	4,0	66,3	89,3
54,6	7,7	4,0	66,3	89,3
54,7	7,7	4,0	66,4	89,4
54,8	7,6	4,0	66,4	89,4
54,9	7,6	4,0	66,5	89,5
<b>55,0</b>	<b>7,5</b>	<b>4,0</b>	<b>66,5</b>	<b>89,5</b>
55,1	7,5	4,0	66,6	89,6
55,2	7,4	4,0	66,6	89,6
55,3	7,4	4,0	66,7	89,7
55,4	7,3	4,0	66,7	89,7
55,5	7,3	4,0	66,8	89,8
55,6	7,2	4,0	66,8	89,8
55,7	7,2	4,0	66,9	89,9
55,8	7,1	4,0	66,9	89,9
55,9	7,1	4,0	67,0	90,0
<b>56,0</b>	<b>7,0</b>	<b>4,0</b>	<b>67,0</b>	<b>90,0</b>
56,1	7,0	4,0	67,1	90,1
56,2	6,9	4,0	67,1	90,1
56,3	6,9	4,0	67,2	90,2
56,4	6,8	4,0	67,2	90,2
56,5	6,8	4,0	67,3	90,3
56,6	6,7	4,0	67,3	90,3

<b>Body Weight</b> <b>BW in kg</b>	<b>Additional Weight</b> <b>AW in kg</b>	<b>Race Clothing</b> <b>RC in kg</b>	<b>Total Weight</b> <b>TW in kg</b>	<b>Total</b> <b>with Sled</b>
56,7	6,7	4,0	67,4	90,4
56,8	6,6	4,0	67,4	90,4
56,9	6,6	4,0	67,5	90,5
<b>57,0</b>	<b>6,5</b>	<b>4,0</b>	<b>67,5</b>	<b>90,5</b>
57,1	6,5	4,0	67,6	90,6
57,2	6,4	4,0	67,6	90,6
57,3	6,4	4,0	67,7	90,7
57,4	6,3	4,0	67,7	90,7
57,5	6,3	4,0	67,8	90,8
57,6	6,2	4,0	67,8	90,8
57,7	6,2	4,0	67,9	90,9
57,8	6,1	4,0	67,9	90,9
57,9	6,1	4,0	68,0	91,0
<b>58,0</b>	<b>6,0</b>	<b>4,0</b>	<b>68,0</b>	<b>91,0</b>
58,1	6,0	4,0	68,1	91,1
58,2	5,9	4,0	68,1	91,1
58,3	5,9	4,0	68,2	91,2
58,4	5,8	4,0	68,2	91,2
58,5	5,8	4,0	68,3	91,3
58,6	5,7	4,0	68,3	91,3
58,7	5,7	4,0	68,4	91,4
58,8	5,6	4,0	68,4	91,4
58,9	5,6	4,0	68,5	91,5
<b>59,0</b>	<b>5,5</b>	<b>4,0</b>	<b>68,5</b>	<b>91,5</b>
59,1	5,5	4,0	68,6	91,6
59,2	5,4	4,0	68,6	91,6
59,3	5,4	4,0	68,7	91,7
59,4	5,3	4,0	68,7	91,7
59,5	5,3	4,0	68,8	91,8
59,6	5,2	4,0	68,8	91,8
59,7	5,2	4,0	68,9	91,9
59,8	5,1	4,0	68,9	91,9

<b>Body Weight</b> <b>BW in kg</b>	<b>Additional Weight</b> <b>AW in kg</b>	<b>Race Clothing</b> <b>RC in kg</b>	<b>Total Weight</b> <b>TW in kg</b>	<b>Total</b> <b>with Sled</b>
59,9	5,1	4,0	69,0	92,0
<b>60,0</b>	<b>5,0</b>	<b>4,0</b>	<b>69,0</b>	<b>92,0</b>
60,1	5,0	4,0	69,1	92,1
60,2	4,9	4,0	69,1	92,1
60,3	4,9	4,0	69,2	92,2
60,4	4,8	4,0	69,2	92,2
60,5	4,8	4,0	69,3	92,3
60,6	4,7	4,0	69,3	92,3
60,7	4,7	4,0	69,4	92,4
60,8	4,6	4,0	69,4	92,4
60,9	4,6	4,0	69,5	92,5
<b>61,0</b>	<b>4,5</b>	<b>4,0</b>	<b>69,5</b>	<b>92,5</b>
61,1	4,5	4,0	69,6	92,6
61,2	4,4	4,0	69,6	92,6
61,3	4,4	4,0	69,7	92,7
61,4	4,3	4,0	69,7	92,7
61,5	4,3	4,0	69,8	92,8
61,6	4,2	4,0	69,8	92,8
61,7	4,2	4,0	69,9	92,9
61,8	4,1	4,0	69,9	92,9
61,9	4,1	4,0	70,0	93,0
<b>62,0</b>	<b>4,0</b>	<b>4,0</b>	<b>70,0</b>	<b>93,0</b>
62,1	4,0	4,0	70,1	93,1
62,2	3,9	4,0	70,1	93,1
62,3	3,9	4,0	70,2	93,2
62,4	3,8	4,0	70,2	93,2
62,5	3,8	4,0	70,3	93,3
62,6	3,7	4,0	70,3	93,3
62,7	3,7	4,0	70,4	93,4
62,8	3,6	4,0	70,4	93,4
62,9	3,6	4,0	70,5	93,5
<b>63,0</b>	<b>3,5</b>	<b>4,0</b>	<b>70,5</b>	<b>93,5</b>

<b>Body Weight</b>	<b>Additional Weight</b>	<b>Race Clothing</b>	<b>Total Weight</b>	<b>Total</b>
<b>BW in kg</b>	<b>AW in kg</b>	<b>RC in kg</b>	<b>TW in kg</b>	<b>with Sled</b>
63,1	3,5	4,0	70,6	93,6
63,2	3,4	4,0	70,6	93,6
63,3	3,4	4,0	70,7	93,7
63,4	3,3	4,0	70,7	93,7
63,5	3,3	4,0	70,8	93,8
63,6	3,2	4,0	70,8	93,8
63,7	3,2	4,0	70,9	93,9
63,8	3,1	4,0	70,9	93,9
63,9	3,1	4,0	71,0	94,0
<b>64,0</b>	<b>3,0</b>	<b>4,0</b>	<b>71,0</b>	<b>94,0</b>
64,1	3,0	4,0	71,1	94,1
64,2	2,9	4,0	71,1	94,1
64,3	2,9	4,0	71,2	94,2
64,4	2,8	4,0	71,2	94,2
64,5	2,8	4,0	71,3	94,3
64,6	2,7	4,0	71,3	94,3
64,7	2,7	4,0	71,4	94,4
64,8	2,6	4,0	71,4	94,4
64,9	2,6	4,0	71,5	94,5
<b>65,0</b>	<b>2,5</b>	<b>4,0</b>	<b>71,5</b>	<b>94,5</b>
65,1	2,5	4,0	71,6	94,6
65,2	2,4	4,0	71,6	94,6
65,3	2,4	4,0	71,7	94,7
65,4	2,3	4,0	71,7	94,7
65,5	2,3	4,0	71,8	94,8
65,6	2,2	4,0	71,8	94,8
65,7	2,2	4,0	71,9	94,9
65,8	2,1	4,0	71,9	94,9
65,9	2,1	4,0	72,0	95,0
<b>66,0</b>	<b>2,0</b>	<b>4,0</b>	<b>72,0</b>	<b>95,0</b>
66,1	2,0	4,0	72,1	95,1
66,2	1,9	4,0	72,1	95,1

<b>Body Weight</b> <b>BW in kg</b>	<b>Additional Weight</b> <b>AW in kg</b>	<b>Race Clothing</b> <b>RC in kg</b>	<b>Total Weight</b> <b>TW in kg</b>	<b>Total</b> <b>with Sled</b>
66,3	1,9	4,0	72,2	95,2
66,4	1,8	4,0	72,2	95,2
66,5	1,8	4,0	72,3	95,3
66,6	1,7	4,0	72,3	95,3
66,7	1,7	4,0	72,4	95,4
66,8	1,6	4,0	72,4	95,4
66,9	1,6	4,0	72,5	95,5
<b>67,0</b>	<b>1,5</b>	<b>4,0</b>	<b>72,5</b>	<b>95,5</b>
67,1	1,5	4,0	72,6	95,6
67,2	1,4	4,0	72,6	95,6
67,3	1,4	4,0	72,7	95,7
67,4	1,3	4,0	72,7	95,7
67,5	1,3	4,0	72,8	95,8
67,6	1,2	4,0	72,8	95,8
67,7	1,2	4,0	72,9	95,9
67,8	1,1	4,0	72,9	95,9
67,9	1,1	4,0	73,0	96,0
<b>68,0</b>	<b>1,0</b>	<b>4,0</b>	<b>73,0</b>	<b>96,0</b>
68,1	1,0	4,0	73,1	96,1
68,2	0,9	4,0	73,1	96,1
68,3	0,9	4,0	73,2	96,2
68,4	0,8	4,0	73,2	96,2
68,5	0,8	4,0	73,3	96,3
68,6	0,7	4,0	73,3	96,3
68,7	0,7	4,0	73,4	96,4
68,8	0,6	4,0	73,4	96,4
68,9	0,6	4,0	73,5	96,5
<b>69,0</b>	<b>0,5</b>	<b>4,0</b>	<b>73,5</b>	<b>96,5</b>
69,1	0,5	4,0	73,6	96,6
69,2	0,4	4,0	73,6	96,6
69,3	0,4	4,0	73,7	96,7
69,4	0,3	4,0	73,7	96,7

<b>Body Weight</b> <b>BW in kg</b>	<b>Additional Weight</b> <b>AW in kg</b>	<b>Race Clothing</b> <b>RC in kg</b>	<b>Total Weight</b> <b>TW in kg</b>	<b>Total</b> <b>with Sled</b>
69,5	0,3	4,0	73,8	96,8
69,6	0,2	4,0	73,8	96,8
69,7	0,2	4,0	73,9	96,9
69,8	0,1	4,0	73,9	96,9
69,9	0,1	4,0	74,0	97,0
<b>70,0</b>	<b>0,0</b>	<b>4,0</b>	<b>74,0</b>	<b>97,0</b>

**Youth A Doubles:**

AW = 50% of the difference between 75 kg and BW (max. 10 kg)

TW = BW + AW + 4 kg RC

<b>Body Weight</b>	<b>Additional Weight</b>	<b>Race Clothing</b>	<b>Total Weight</b>	<b>Total</b>
<b>BW in kg</b>	<b>AW in kg</b>	<b>RC in kg</b>	<b>TW in kg</b>	<b>with Sled</b>
<b>55,0</b>	<b>10,0</b>	<b>4,0</b>	<b>69,0</b>	<b>96,0</b>
55,1	9,9	4,0	69,0	96,0
55,2	9,9	4,0	69,1	96,1
55,3	9,8	4,0	69,1	96,1
55,4	9,8	4,0	69,2	96,2
55,5	9,7	4,0	69,2	96,2
55,6	9,7	4,0	69,3	96,3
55,7	9,6	4,0	69,3	96,3
55,8	9,6	4,0	69,4	96,4
55,9	9,5	4,0	69,4	96,4
<b>56,0</b>	<b>9,5</b>	<b>4,0</b>	<b>69,5</b>	<b>96,5</b>
56,1	9,4	4,0	69,5	96,5
56,2	9,4	4,0	69,6	96,6
56,3	9,3	4,0	69,6	96,6
56,4	9,3	4,0	69,7	96,7
56,5	9,2	4,0	69,7	96,7
56,6	9,2	4,0	69,8	96,8
56,7	9,1	4,0	69,8	96,8
56,8	9,1	4,0	69,9	96,9
56,9	9,0	4,0	69,9	96,9
<b>57,0</b>	<b>9,0</b>	<b>4,0</b>	<b>70,0</b>	<b>97,0</b>
57,1	8,9	4,0	70,0	97,0
57,2	8,9	4,0	70,1	97,1
57,3	8,8	4,0	70,1	97,1
57,4	8,8	4,0	70,2	97,2
57,5	8,7	4,0	70,2	97,2
57,6	8,7	4,0	70,3	97,3
57,7	8,6	4,0	70,3	97,3
57,8	8,6	4,0	70,4	97,4

<b>Body Weight</b>	<b>Additional Weight</b>	<b>Race Clothing</b>	<b>Total Weight</b>	<b>Total</b>
<b>BW in kg</b>	<b>AW in kg</b>	<b>RC in kg</b>	<b>TW in kg</b>	<b>with Sled</b>
57,9	8,5	4,0	70,4	97,4
<b>58,0</b>	<b>8,5</b>	<b>4,0</b>	<b>70,5</b>	<b>97,5</b>
58,1	8,4	4,0	70,5	97,5
58,2	8,4	4,0	70,6	97,6
58,3	8,3	4,0	70,6	97,6
58,4	8,3	4,0	70,7	97,7
58,5	8,2	4,0	70,7	97,7
58,6	8,2	4,0	70,8	97,8
58,7	8,1	4,0	70,8	97,8
58,8	8,1	4,0	70,9	97,9
58,9	8,0	4,0	70,9	97,9
<b>59,0</b>	<b>8,0</b>	<b>4,0</b>	<b>71,0</b>	<b>98,0</b>
59,1	7,9	4,0	71,0	98,0
59,2	7,9	4,0	71,1	98,1
59,3	7,8	4,0	71,1	98,1
59,4	7,8	4,0	71,2	98,2
59,5	7,7	4,0	71,2	98,2
59,6	7,7	4,0	71,3	98,3
59,7	7,6	4,0	71,3	98,3
59,8	7,6	4,0	71,4	98,4
59,9	7,5	4,0	71,4	98,4
<b>60,0</b>	<b>7,5</b>	<b>4,0</b>	<b>71,5</b>	<b>98,5</b>
60,1	7,4	4,0	71,5	98,5
60,2	7,4	4,0	71,6	98,6
60,3	7,3	4,0	71,6	98,6
60,4	7,3	4,0	71,7	98,7
60,5	7,2	4,0	71,7	98,7
60,6	7,2	4,0	71,8	98,8
60,7	7,1	4,0	71,8	98,8
60,8	7,1	4,0	71,9	98,9
60,9	7,0	4,0	71,9	98,9
<b>61,0</b>	<b>7,0</b>	<b>4,0</b>	<b>72,0</b>	<b>99,0</b>
61,1	6,9	4,0	72,0	99,0



<b>Body Weight</b> <b>BW in kg</b>	<b>Additional Weight</b> <b>AW in kg</b>	<b>Race Clothing</b> <b>RC in kg</b>	<b>Total Weight</b> <b>TW in kg</b>	<b>Total with Sled</b>
61,2	6,9	4,0	72,1	99,1
61,3	6,8	4,0	72,1	99,1
61,4	6,8	4,0	72,2	99,2
61,5	6,7	4,0	72,2	99,2
61,6	6,7	4,0	72,3	99,3
61,7	6,6	4,0	72,3	99,3
61,8	6,6	4,0	72,4	99,4
61,9	6,5	4,0	72,4	99,4
<b>62,0</b>	<b>6,5</b>	<b>4,0</b>	<b>72,5</b>	<b>99,5</b>
62,1	6,4	4,0	72,5	99,5
62,2	6,4	4,0	72,6	99,6
62,3	6,3	4,0	72,6	99,6
62,4	6,3	4,0	72,7	99,7
62,5	6,2	4,0	72,7	99,7
62,6	6,2	4,0	72,8	99,8
62,7	6,1	4,0	72,8	99,8
62,8	6,1	4,0	72,9	99,9
62,9	6,0	4,0	72,9	99,9
<b>63,0</b>	<b>6,0</b>	<b>4,0</b>	<b>73,0</b>	<b>100,0</b>
63,1	5,9	4,0	73,0	100,0
63,2	5,9	4,0	73,1	100,1
63,3	5,8	4,0	73,1	100,1
63,4	5,8	4,0	73,2	100,2
63,5	5,7	4,0	73,2	100,2
63,6	5,7	4,0	73,3	100,3
63,7	5,6	4,0	73,3	100,3
63,8	5,6	4,0	73,4	100,4
63,9	5,5	4,0	73,4	100,4
<b>64,0</b>	<b>5,5</b>	<b>4,0</b>	<b>73,5</b>	<b>100,5</b>
64,1	5,4	4,0	73,5	100,5
64,2	5,4	4,0	73,6	100,6
64,3	5,3	4,0	73,6	100,6
64,4	5,3	4,0	73,7	100,7

<b>Body Weight</b> <b>BW in kg</b>	<b>Add. Weight</b> <b>AW in kg</b>	<b>Race Clothing</b> <b>RC in kg</b>	<b>Total Weight</b> <b>TW in kg</b>	<b>Total</b> <b>with Sled</b>
64,5	5,2	4,0	73,7	100,7
64,6	5,2	4,0	73,8	100,8
64,7	5,1	4,0	73,8	100,8
64,8	5,1	4,0	73,9	100,9
64,9	5,0	4,0	73,9	100,9
<b>65,0</b>	<b>5,0</b>	<b>4,0</b>	<b>74,0</b>	<b>101,0</b>
65,1	4,9	4,0	74,0	101,0
65,2	4,9	4,0	74,1	101,1
65,3	4,8	4,0	74,1	101,1
65,4	4,8	4,0	74,2	101,2
65,5	4,7	4,0	74,2	101,2
65,6	4,7	4,0	74,3	101,3
65,7	4,6	4,0	74,3	101,3
65,8	4,6	4,0	74,4	101,4
65,9	4,5	4,0	74,4	101,4
<b>66,0</b>	<b>4,5</b>	<b>4,0</b>	<b>74,5</b>	<b>101,5</b>
66,1	4,4	4,0	74,5	101,5
66,2	4,4	4,0	74,6	101,6
66,3	4,3	4,0	74,6	101,6
66,4	4,3	4,0	74,7	101,7
66,5	4,2	4,0	74,7	101,7
66,6	4,2	4,0	74,8	101,8
66,7	4,1	4,0	74,8	101,8
66,8	4,1	4,0	74,9	101,9
66,9	4,0	4,0	74,9	101,9
<b>67,0</b>	<b>4,0</b>	<b>4,0</b>	<b>75,0</b>	<b>102,0</b>
67,1	3,9	4,0	75,0	102,0
67,2	3,9	4,0	75,1	102,1
67,3	3,8	4,0	75,1	102,1
67,4	3,8	4,0	75,2	102,2
67,5	3,7	4,0	75,2	102,2
67,6	3,7	4,0	75,3	102,3
67,7	3,6	4,0	75,3	102,3

<b>Body Weight</b>	<b>Add. Weight</b>	<b>Race Clothing</b>	<b>Total Weight</b>	<b>Total</b>
<b>BW in kg</b>	<b>AW in kg</b>	<b>RC in kg</b>	<b>TW in kg</b>	<b>with Sled</b>
67,8	3,6	4,0	75,4	102,4
67,9	3,5	4,0	75,4	102,4
<b>68,0</b>	<b>3,5</b>	<b>4,0</b>	<b>75,5</b>	<b>102,5</b>
68,1	3,4	4,0	75,5	102,5
68,2	3,4	4,0	75,6	102,6
68,3	3,3	4,0	75,6	102,6
68,4	3,3	4,0	75,7	102,7
68,5	3,2	4,0	75,7	102,7
68,6	3,2	4,0	75,8	102,8
68,7	3,1	4,0	75,8	102,8
68,8	3,1	4,0	75,9	102,9
68,9	3,0	4,0	75,9	102,9
<b>69,0</b>	<b>3,0</b>	<b>4,0</b>	<b>76,0</b>	<b>103,0</b>
69,1	2,9	4,0	76,0	103,0
69,2	2,9	4,0	76,1	103,1
69,3	2,8	4,0	76,1	103,1
69,4	2,8	4,0	76,2	103,2
69,5	2,7	4,0	76,2	103,2
69,6	2,7	4,0	76,3	103,3
69,7	2,6	4,0	76,3	103,3
69,8	2,6	4,0	76,4	103,4
69,9	2,5	4,0	76,4	103,4
<b>70,0</b>	<b>2,5</b>	<b>4,0</b>	<b>76,5</b>	<b>103,5</b>
70,1	2,4	4,0	76,5	103,5
70,2	2,4	4,0	76,6	103,6
70,3	2,3	4,0	76,6	103,6
70,4	2,3	4,0	76,7	103,7
70,5	2,2	4,0	76,7	103,7
70,6	2,2	4,0	76,8	103,8
70,7	2,1	4,0	76,8	103,8
70,8	2,1	4,0	76,9	103,9
70,9	2,0	4,0	76,9	103,9
<b>71,0</b>	<b>2,0</b>	<b>4,0</b>	<b>77,0</b>	<b>104,0</b>

<b>Body Weight</b>	<b>Additional Weight</b>	<b>Race Clothing</b>	<b>Total Weight</b>	<b>Total</b>
<b>BW in kg</b>	<b>AW in kg</b>	<b>RC in kg</b>	<b>TW in kg</b>	<b>with Sled</b>
71,1	1,9	4,0	77,0	104,0
71,2	1,9	4,0	77,1	104,1
71,3	1,8	4,0	77,1	104,1
71,4	1,8	4,0	77,2	104,2
71,5	1,7	4,0	77,2	104,2
71,6	1,7	4,0	77,3	104,3
71,7	1,6	4,0	77,3	104,3
71,8	1,6	4,0	77,4	104,4
71,9	1,5	4,0	77,4	104,4
<b>72,0</b>	<b>1,5</b>	<b>4,0</b>	<b>77,5</b>	<b>104,5</b>
72,1	1,4	4,0	77,5	104,5
72,2	1,4	4,0	77,6	104,6
72,3	1,3	4,0	77,6	104,6
72,4	1,3	4,0	77,7	104,7
72,5	1,2	4,0	77,7	104,7
72,6	1,2	4,0	77,8	104,8
72,7	1,1	4,0	77,8	104,8
72,8	1,1	4,0	77,9	104,9
72,9	1,0	4,0	77,9	104,9
<b>73,0</b>	<b>1,0</b>	<b>4,0</b>	<b>78,0</b>	<b>105,0</b>
73,1	0,9	4,0	78,0	105,0
73,2	0,9	4,0	78,1	105,1
73,3	0,8	4,0	78,1	105,1
73,4	0,8	4,0	78,2	105,2
73,5	0,7	4,0	78,2	105,2
73,6	0,7	4,0	78,3	105,3
73,7	0,6	4,0	78,3	105,3
73,8	0,6	4,0	78,4	105,4
73,9	0,5	4,0	78,4	105,4
<b>74,0</b>	<b>0,5</b>	<b>4,0</b>	<b>78,5</b>	<b>105,5</b>
74,1	0,4	4,0	78,5	105,5
74,2	0,4	4,0	78,6	105,6
74,3	0,3	4,0	78,6	105,6

<b>Body Weight</b>	<b>Additional Weight</b>	<b>Race Clothing</b>	<b>Total Weight</b>	<b>Total</b>
<b>BW in kg</b>	<b>AW in kg</b>	<b>RC in kg</b>	<b>TW in kg</b>	<b>with Sled</b>
74,4	0,3	4,0	78,7	105,7
74,5	0,2	4,0	78,7	105,7
74,6	0,2	4,0	78,8	105,8
74,7	0,1	4,0	78,8	105,8
74,8	0,1	4,0	78,9	105,9
74,9	0,0	4,0	78,9	105,9
<b>75,0</b>	<b>0,0</b>	<b>4,0</b>	<b>79,0</b>	<b>106,0</b>